

**CCS Technical Documentation
NHL-2NA Series Transceiver**

Troubleshooting Instructions

[This page left intentionally blank]

Table of Contents

Baseband Troubleshooting.....	1
Introduction	1
General guidelines for NHL-2NA system troubleshooting	1
Tools needed for troubleshooting.....	1
General guidelines.....	1
Nominal current consumption	2
Troubleshooting paths	4
Dead or jammed device.....	4
Partially damaged device	5
Most common symptoms reported by customer	5
Contact the retailer” on display	6
LG4 Baseband HW subarea troubleshooting	8
Flashing troubleshooting.....	8
Energy management troubleshooting	10
Device does not stay on.....	10
General power checking.....	10
SMPS of AEM troubleshooting	12
Power key troubleshooting.....	13
Clocks troubleshooting.....	14
Charging checking.....	17
Energy management calibration.....	20
ADC-reading	21
Backup battery.....	21
IR interface	23
Sensors troubleshooting	25
Proximity Detector	26
General notes.....	26
Proximity Detector components.....	26
Handsfree shuts down automatically in sunshine	27
PD calibration.....	27
Troubleshooting with PD Calibration results.....	28
Ambient Light Detector	32
General Notes.....	32
Ambient Light Detector	33
Problems from the user point of view	34
SIM card	38
"Insert SIM Card" in device display although card is inserted	41
Audio	42
Microphone	42
Earpiece.....	43
IHF	44
Accessory detection troubleshooting	45
Memory troubleshooting	46
Baseband serial interface troubleshooting	47
CBUS	47

FBUS.....	49
MBUS.....	49
Hall sensor troubleshooting	50
Display backlights troubleshooting	51
Bluetooth troubleshooting	52
Needed actions if ASIC is changed.....	54
UEM changed	54
AEM changed	54
UPP_WD2 changed	54
Flash0 changed	54
RF component changed	54
Test points and pin orders	55
Test points in BaseBand area (LG4_06_02)	55
Connectors pin order	57
UI-connector.....	57
Board to board connector	59
Pin order of spring connectors	59
RF Troubleshooting	1
Introduction	1
RF Key component placement	2
Fault finding test point locations	3
Receiver	4
General description	4
E-GSM900	5
GSM1800	8
Picture of RX signal	10
Transmitter	11
General description	11
E-GSM900	12
GSM1800	13
Fault finding tree	14
Example of TX signals	15
Common	17
Antenna switch control logic (reference Z672).....	17
VCTCXO (reference G591)	17
Frequency synthesizer	18
HAGAR.....	21
PA and Antenna switch	22
Receiver tunings	23
RX Channel Select Filter Calibration.....	23
RX Calibration	24
RX Band Filter Response Compensation	28
RX AM Suppression	33
Transmitter Tunings	36
TX I/Q Tuning.....	36
TX Power Level Tuning.....	38
Appendix.....	43
Frequency mappings	43

E-GSM900	44
GSM1800	46
UI Troubleshooting	1
Introduction	1
UI module troubleshooting cases	1
Display blank.....	1
Image on display not correct	2
Key or 5-way switch not working	4
Grip-Module Troubleshooting	1
Introduction	1
Backlight	2
Current Gauge	3
Vibra	4
Keyboard	5
Hall Sensor	6
Camera Troubleshooting Instructions	1
Background, tools and terminology	1
Terms.....	1
Image taking conditions effect to image quality	2
Camera construction	8
Image quality analysis	9
Possible faults in image quality.....	9
Testing for dust.....	9
Testing for sharpness.....	10
Bit errors.....	14
Fault finding trees	15
Hardware failure message	15
No recognizable viewfinder image	17
Bad image quality.....	18

Baseband Troubleshooting

Introduction

This document is intended to be a guide for localising and repairing electrical faults in the NHL-2NA device. First there is a brief guide for fault localising. Then fault repairing is divided into troubleshooting paths.

Before any service operation you must be familiar with the NHL-2NA product and module level architecture. You also have to be familiar with the NHL-2NA specified service tools such as the Phoenix service software, flashing tools and software.

General guidelines for NHL-2NA system troubleshooting

Tools needed for troubleshooting

- Service tools (as listed at service tools chapter in service manual)
- Laboratory power supply with current indicator
- Oscilloscope
- Digital multimeter

General guidelines

General notes about the NHL-2NA product:

- Large colour display
- Keyboard on grip part, rocker, two softkeys and application key under display + side keys (power key and IHF enabling key)
- Flex cable carries signals between LG4 and LS4 boards. Battery and charger plug is in grip part, so if the flex is damaged phone cannot be powered on.
- UI-module (display, backlights etc.) is also connected to LG4 module with flex cable.
- If the component reference is under 100, component is located at the LS4 board. And if the component reference is over 100, component is located at the LG4 board.

When you get a faulty NHL-2NA device and you start to troubleshoot it, first check the following items:

- If the device cannot be turned on by any means, see "dead device" troubleshooting
- Current consumption (missing consumption) gives an idea whether the device is able to start up.
- Dropping supply voltage or very large current consumption indicates a short circuit
- Check whether the connection with Phoenix works and what can be discovered with Phoenix (ADC-readings, baseband selftest, bb-calibrations etc.)
- Check baseband selftests with Phoenix if "CONTACT THE RETAILER." is shown on the display.
- Check visually display and rocker faults
- Force phone to LOCAL mode and make keyboard test by phoenix

- Check that board-to-board connector, hotbar and adapter connections are OK, and connectors make good contacts.
- If liquid damage, stop repairing!

If some module (eg. Camera, display, grip) is not working:

- Try working module

If this not helping

- Check supply voltages for failed module
- Check clock(s) for failed module

=> Go to relevant chapter of this document

Flash phone before disassembling it if fault is not obvious and Phoenix connection is OK.

Dissassemble phone:

Try to locate failed module, is it LG4, LS4, UI or camera module.

- Check failed module visually:

Mechanical damages?

Solder joints OK?

Continue with specific troubleshooting procedure for the module:

- If there is an obvious fault, repair it before reflashing the device
- Flash first if a fault is not obvious

If flashing is not working go to flashing troubleshooting

Due to CSP packages short circuits or broken solder joints are not easily seen. If the examined signal seems to be continuously in low or high level, then measure for possible short circuit to ground (signal low) or to supply voltage (signal high) Note that if a problem is not found from any visible contact/component it can be under CSPs where the signal is connected.

Care must be taken when assembling and disassembling the transceiver. Failure to do this may result in unnecessary damage to device.

NOTE! if some ASIC is changed see chapter Bluetooth troubleshooting

Nominal current consumption

NOTE: Service tools need some amount of current to work. (FLA-21: 1-2mA and MJF-9Q: 2-6mA)

The following current consumption values are measured from a complete NHL-2NA.

Vbatt = 3.8 – 4.2V

Measured nominal currents are drawn from the main battery.

Measurements have been made with a current probe connected to an oscilloscope.

<u>Operating mode</u>	<u>Current consumption</u>
Idle (BT off)	4-8 mA
2w audio call (backlights off) channel37	300-340mA
Viewfinder + nominal backlights	232mA

Troubleshooting paths

Dead or jammed device

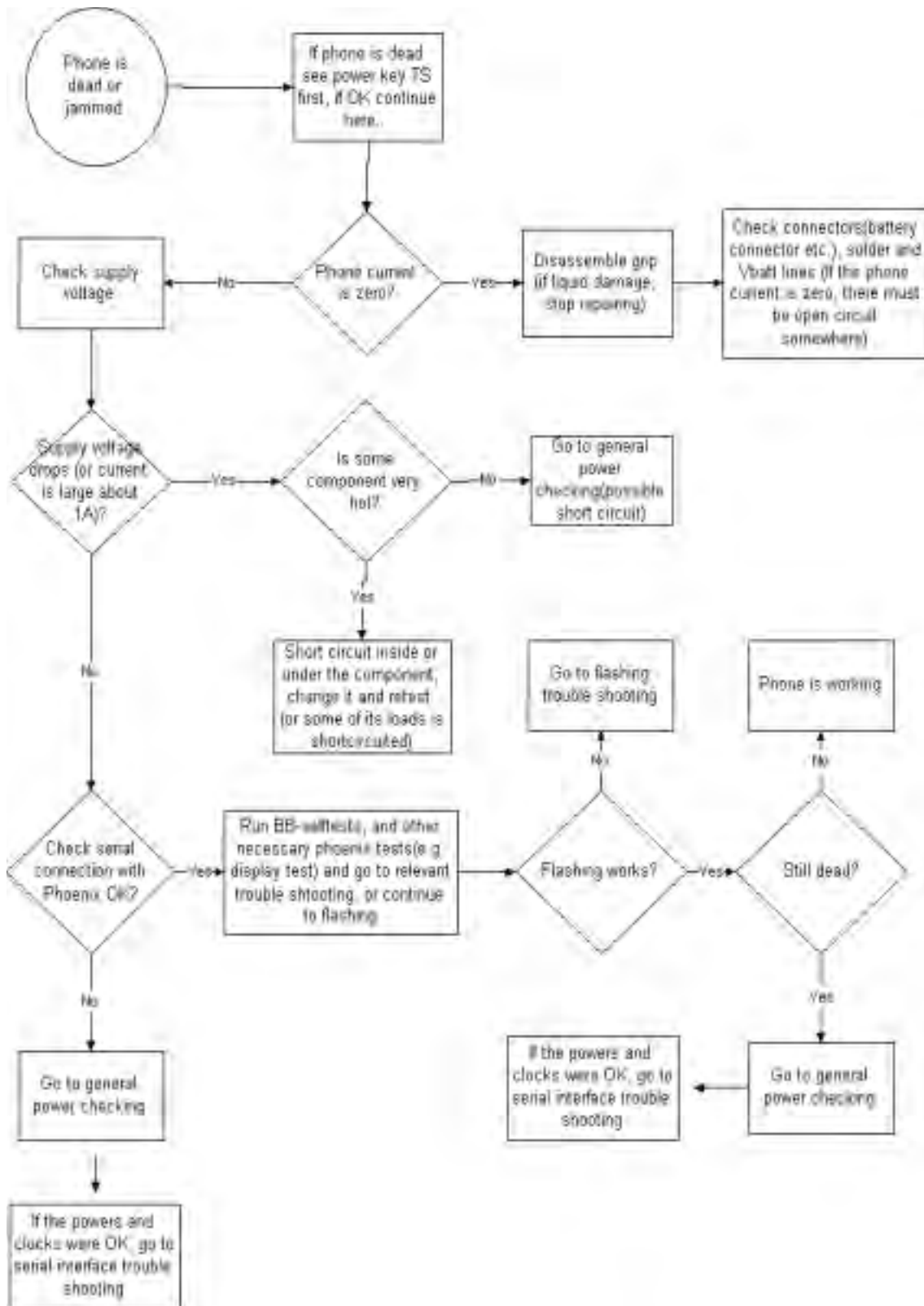

Partially damaged device

If the device is working, but some functionality is missing try to localize where the problem is and see relevant part of this manual. If, for example, audio is not working see chapter Audio Troubleshooting, if charging is not working see chapter Charging Troubleshooting, etc.

Most common symptoms reported by customer

In this section is described most common symptoms reported by customers when the device is brought to service. Some tips where the trouble can be found are also given. When troubleshooting use these tips and follow the given troubleshooting path.

Most common symptoms for audio problems can be:

- "Earpiece sound is missing"
- "Handsfree sound is missing"
- "Headset is not recognized"
- "Microphone is not working"
- "Volume cannot be adjusted"
- " Ringing tones do not work"
- "Audio volume too low"

If symptom is something like above see audio troubleshooting.

Most common symptoms for Irda and bluetooth problems can be:

- "Irda does not work or it does not make a connection"
- "Bluetooth does not work or connection cannot be established"

If symptoms are something like those, start to follow Irda or bluetooth troubleshooting guidelines gave relevant chapters.

Symptoms related to energy management:

- "Phone does not stay on"
- "Charging is not working"
- "Time is lost during battery change or short main battery removal"
- "Charging takes too long"
- "Operating time is very short"

These symptoms lead to relevant part of energy management troubleshooting

If the sensor/sensors are out of order description of symptoms can be like below:

- "IHF is not disabled automatically when phone is put near ear"
- "IHF cannot be enabled"
- "Backlight is always ON or OFF"
- "Backlight of display does not go OFF"

In cases above see Chapter Sensors Troubleshooting or Backlight Troubleshooting

Problems in UI-module:

- "UI-module keypad is not working"
- "Joystick is not working"
- "Backlight is dim"
- "Backlight not even"
- "Backlight is blinking"
- "Keypad or display backlight is not working"
- "Display related problems"

See UI- module troubleshooting.

Most common RF related symptoms:

- "Call cannot be made"
- "Phone does not find signal"
- "Call is often dropped"

See RF troubleshooting

Problems with camera can cause symptoms as:

- "Bad image quality"
- "Picture cannot be taken"

See camera module troubleshooting

Problems in LS4 can cause symptoms below:

- "Backlight of grip is dim"
- "Backlight of grip not even"
- "Backlight of grip is blinking"
- "Grip keypad is not working"
- "Vibra is not working or is noisy etc."

See grip- module troubleshooting.

Contact the retailer" on display

"Contact the retailer." on display (Self-tests by Phoenix)

Display information: **"Contact the retailer"**

This fault means that software is able to run and thus the watchdog of UEM can be served.

Selftest functions are executed when the phone is powered on and if one or more selftest functions fail, the message “**Contact the retailer**” is shown on the display.

MCU selftest cases can be split into two categories: The ones that are executed during power up and the ones that are executed only with a PC connected. These tests and the items included are as follows:

Figure 1: BB selftest-tool

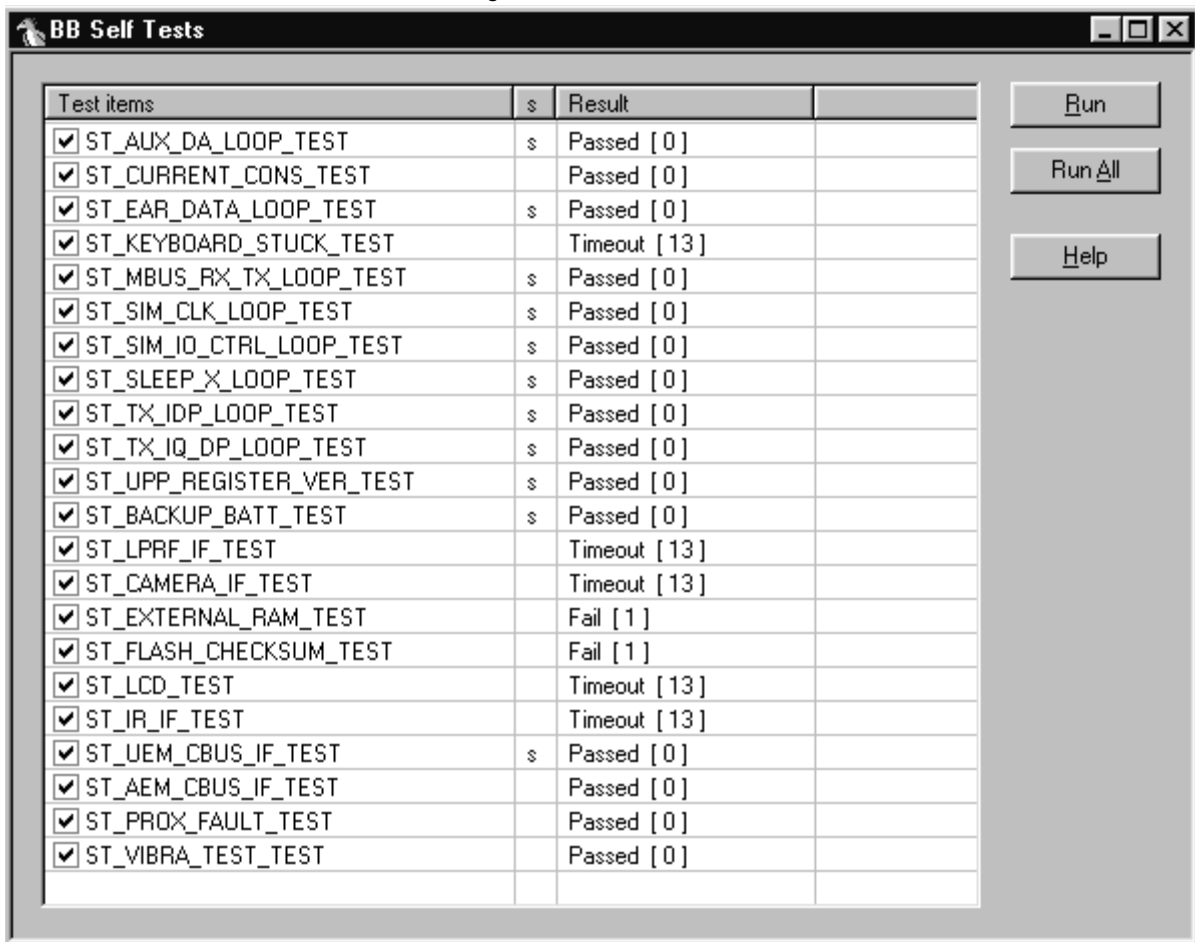

If a selftest fails, see relevant chapter in this troubleshooting manual.

LG4 Baseband HW subarea troubleshooting

Flashing troubleshooting

NHL-2NA has three memory components installed on the main pwb. The best indication of which one is causing problems can be obtained by flashing the device. It has to be kept in mind that all three flashes are interfaced with UPP WD2 asic that might itself have some problems. The necessary steps are described below. Phoenix error messages during flashing greatly help on defining what is wrong. To be able to flash the device, most device BB area components must function properly.

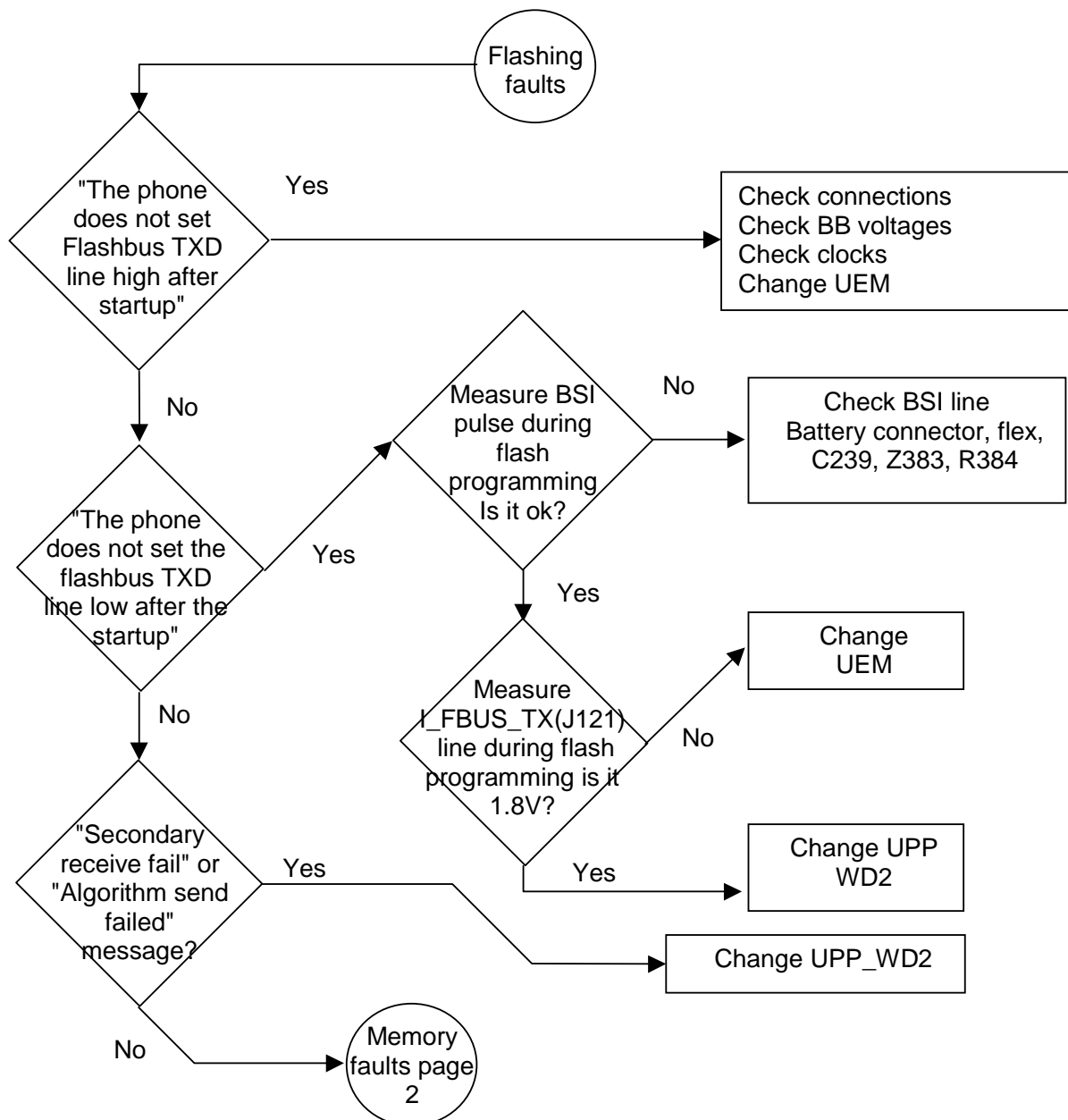

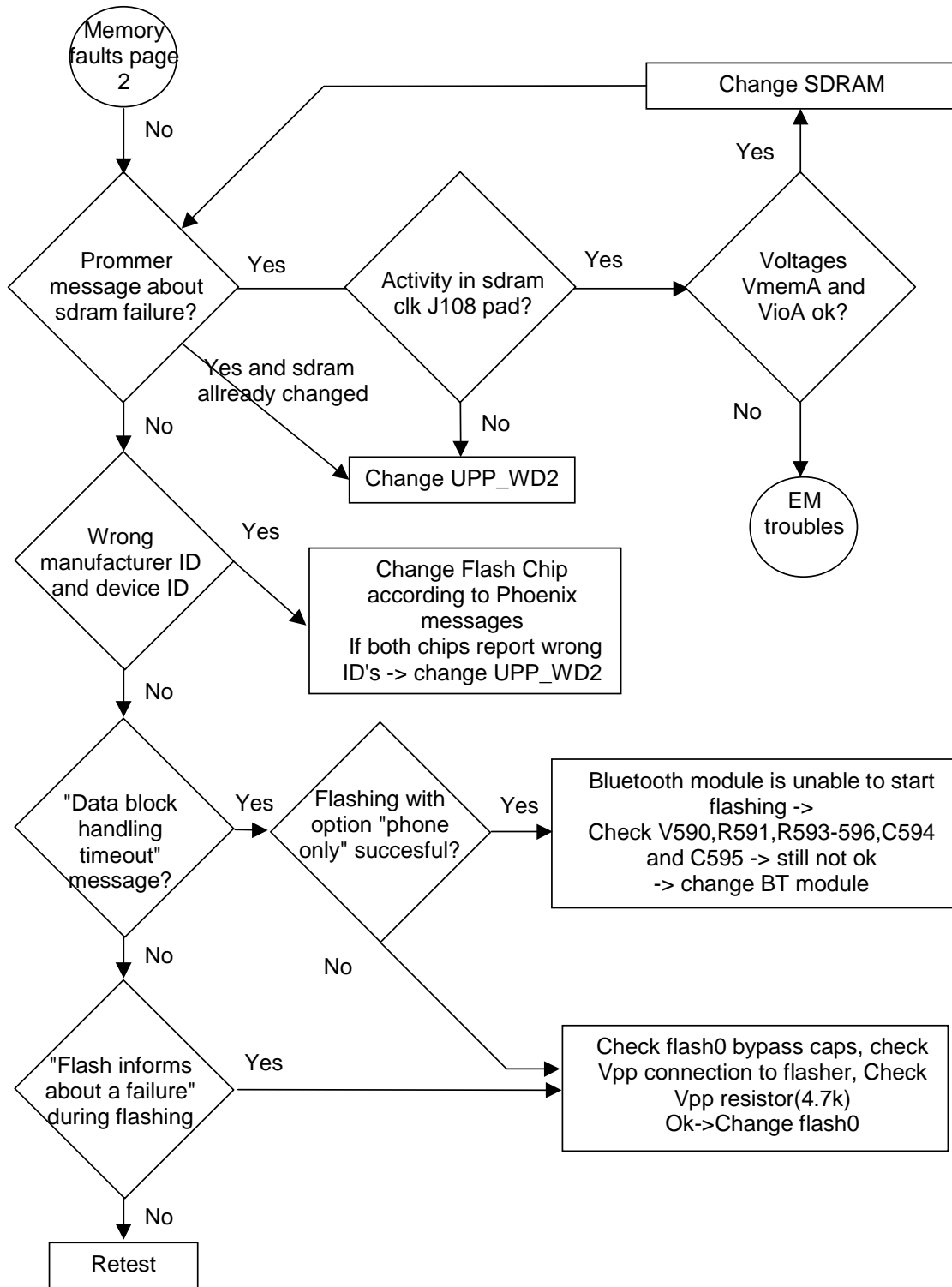

Energy management troubleshooting

Device does not stay on

If the device is switched off without any visible reason, there may be problems in the following areas:

- UEM watchdog problem (WD is not updated by SW)
- BSI line problem (BSI line is floating => contact failure)
- Battery line problem
- Soldering problem

The most likely reason is UEM WD (watchdog), which turns the device off after about 32 seconds if SW is jammed.

This may be caused by a SW problem, UPP_WD2 problem (Not server by SW), UEM, AEM or memory malfunctions.

The following tests are recommended:

- General power checking
- Clocks
- Memory testing
- Serial Interface

If there is something wrong in BSI line, the device seems to be dead after the power key is pressed. However the regulators of the device are on a few seconds before the power-down.

This mode can easily be detected from the current consumption of the device. After a few seconds the current consumption drops almost to 0 mA.

In this case check components listed below or soldering:

Battery connector X002
Grip connector X001 (especially pin number 27)
Hotbar soldering X380 (especially pin number 5)
EMI-filter Z383 (especially pins number A4 and E4)
UEM D190 (pin number C2)

If phone boots to TEST or LOCAL mode with normal battery, BSI or Btemp or both lines are short circuited to ground. Check varistors, EMI-filter and filtering capacitors, which are located to BSI and Btemp lines.

General power checking

Use service tool FLA-21. Battery voltage should be atleast 3.6V. After phone disassembly, use module jig MJS-9Q.

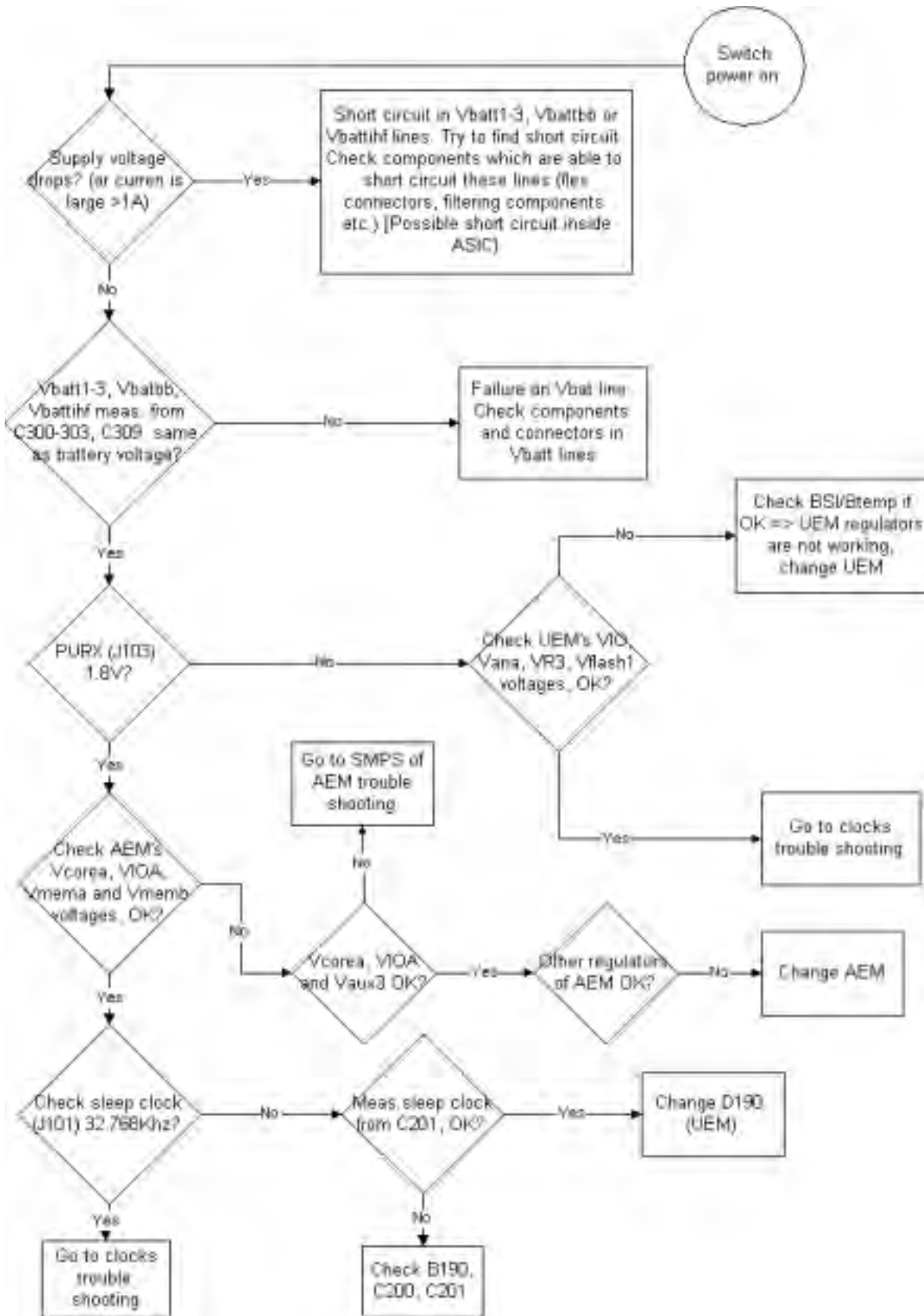

SMPS of AEM troubleshooting

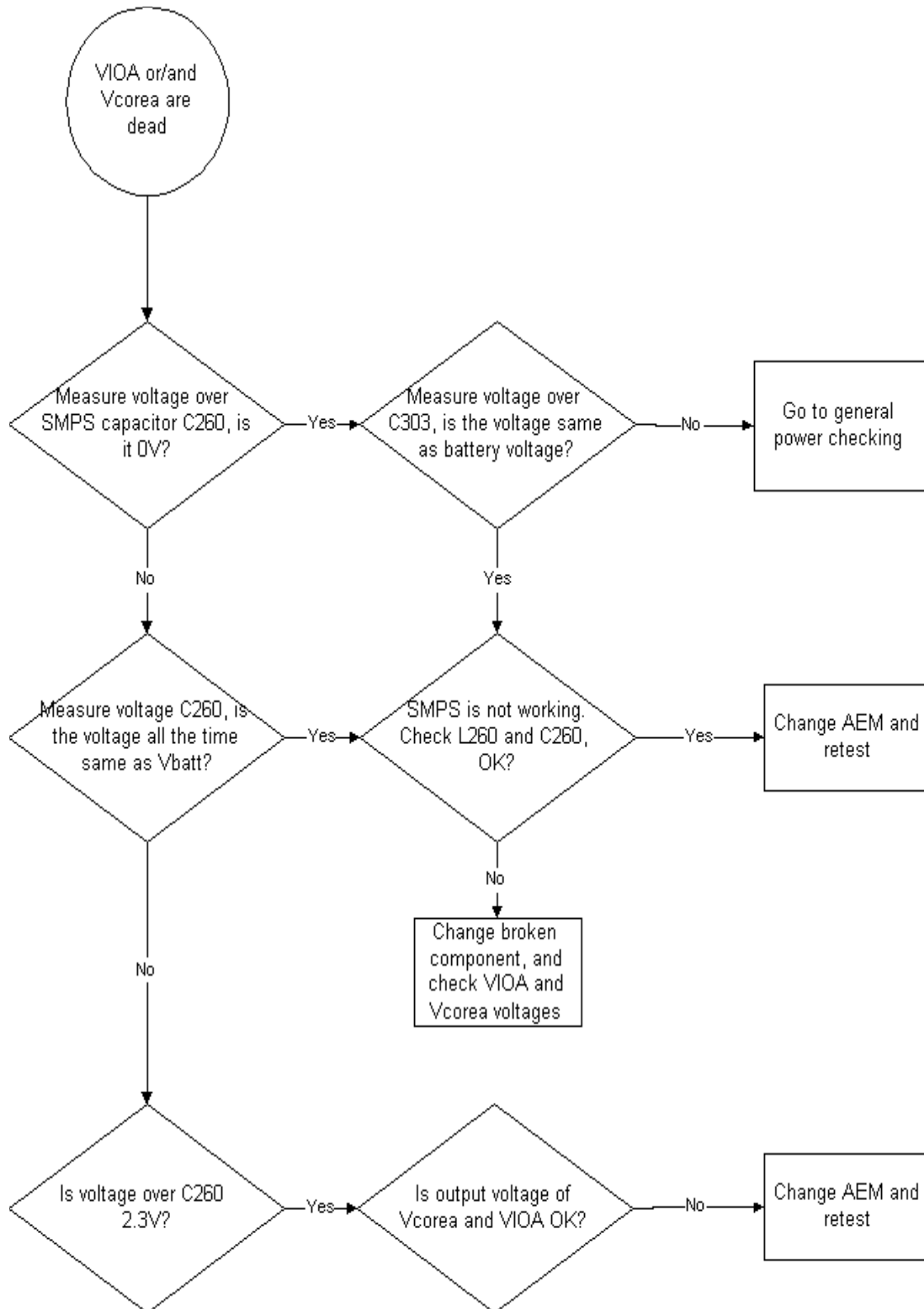

Power key troubleshooting

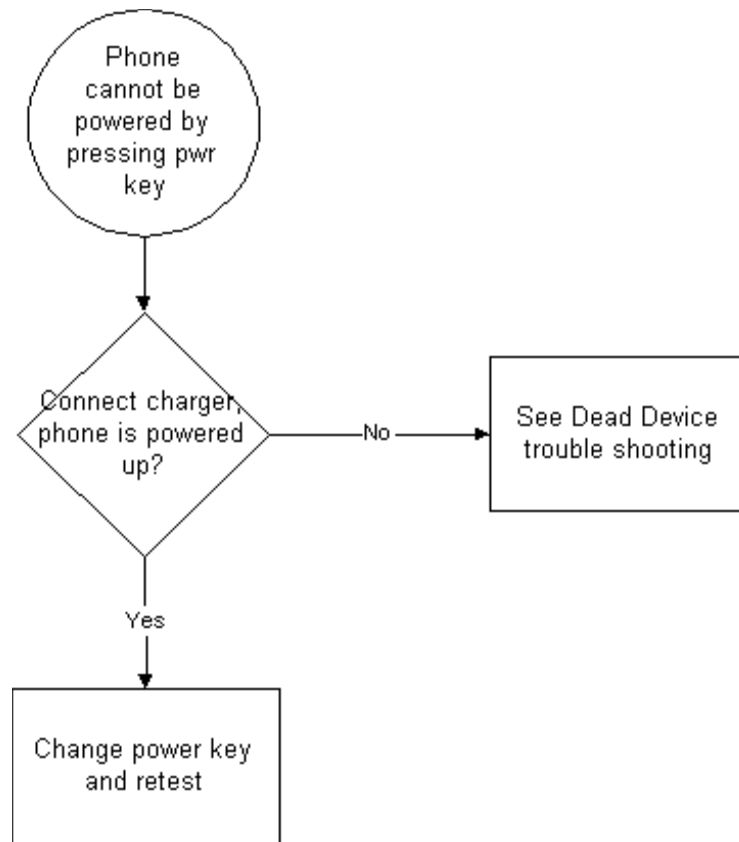

Clocks troubleshooting

The main clock signal for the baseband is generated from the voltage and temperature controlled crystal oscillator VCTCXO (G591). This 26 MHz triangle wave clock signal is supplied to OSC_IN pin of HAGAR. Inside HAGAR the clock frequency is divided to 13 MHz and then fed to RFCLK pin of UPP_WD2 and Bluetooth.

In SLEEP mode the VCTCXO is off. UEM generates low frequency clock signal (32.768 kHz) that is fed to UPP_WD2, Bluetooth and AEM.

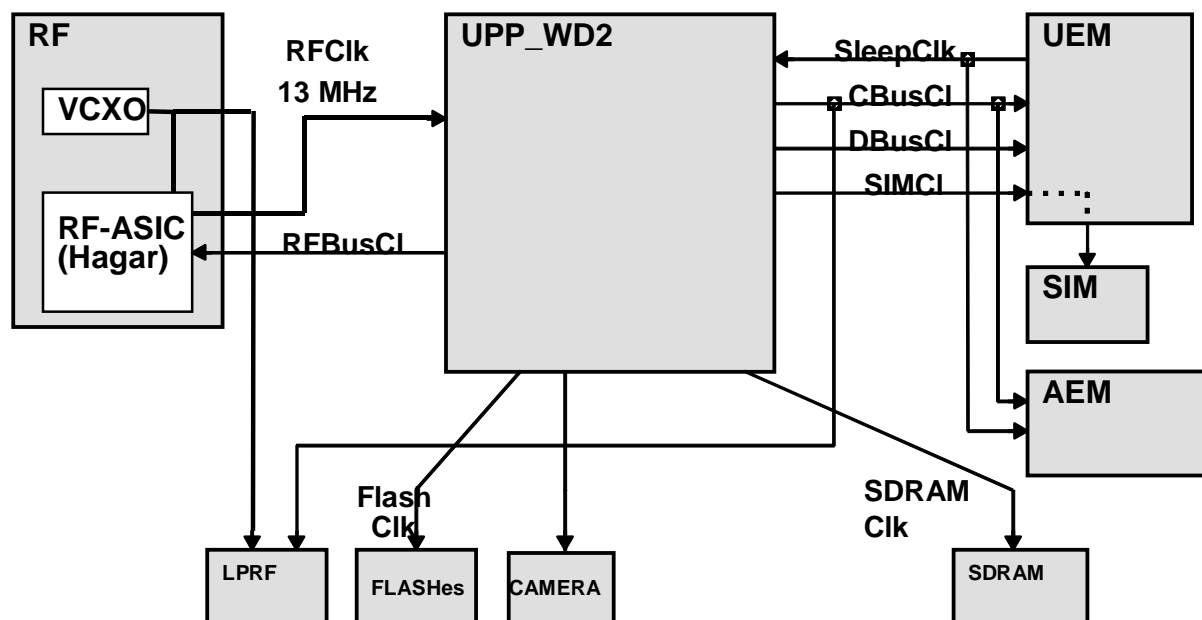

When the flashing of the device does not succeed, but powering is OK, follow these instructions.

Note: The absence of clocks may indicate that the device (put phone to LOCAL mode when the sleep is not allowed or press buttons so that phone is not in sleep mode) is in sleep mode. Make sure that the device is not in sleep during RF clock measuring.

IMPORTANT: Clock signals have to be measured with $1M\Omega$ (or greater) probes!

- 1 Measure signal from R596. This should be 26Mhz clock signal. See figure below. If the clock not exist, check voltage from C662, it should be 2.78V (UEM regulator VR3). If voltage is OK, check G591 and other componets around it.

Figure 2: 26 Mhz clock

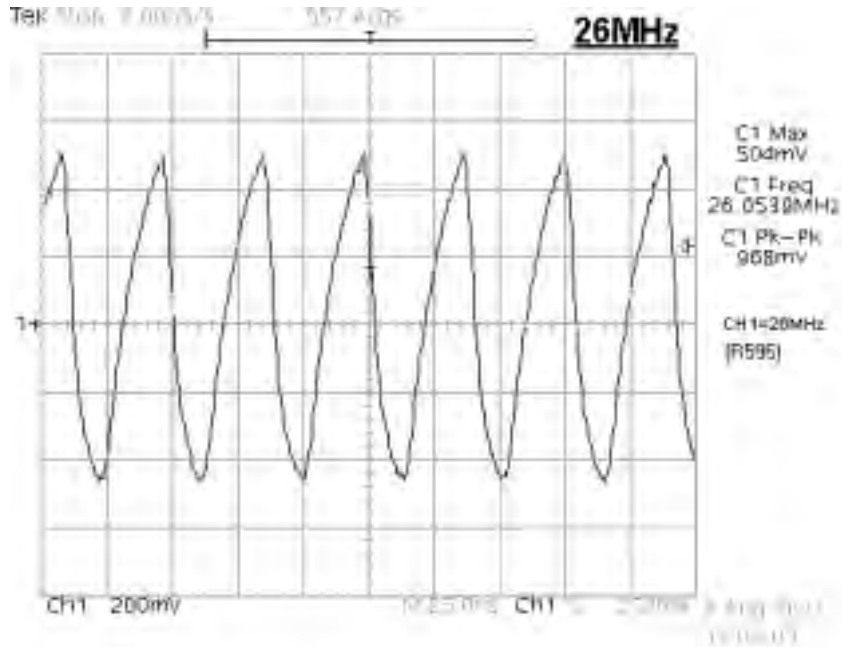

- 2 Check 13Mhz Rfclk from testpoint J100. See figure below. Offset should be about 900mV. If the offset does not exist something is broken inside UPP_WD2 or DC-filtering capacitor in series on trace.

Figure 3: 13 MHz clock

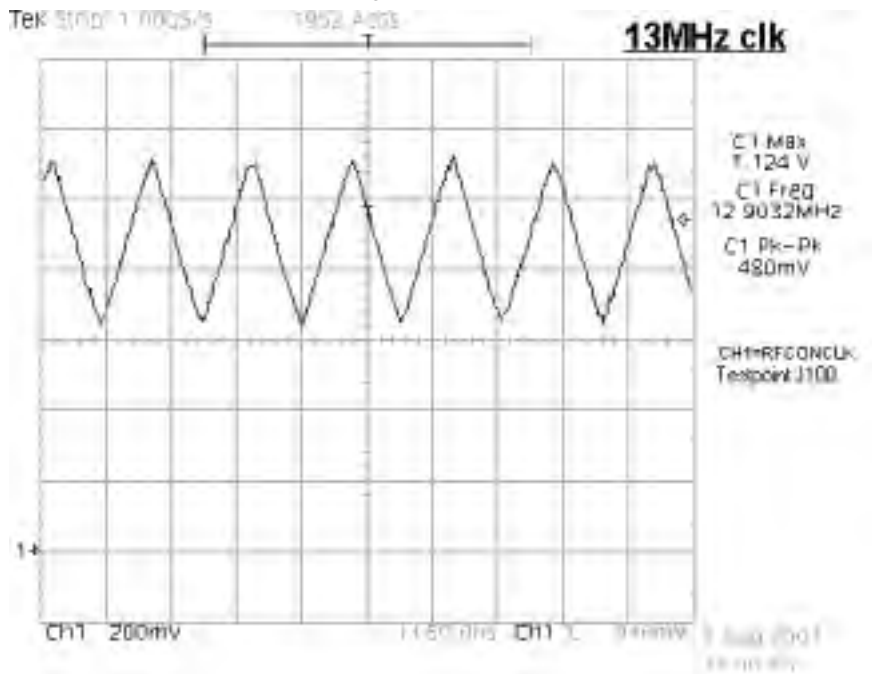

- 3 Check is the crystal oscillator (B190) oscillating at 32.768kHz frequency. If not change B190. If OK measure sleepclk from testpoint J101. Frequency should be the same 32.678kHz (see figure below.) If not change UEM.

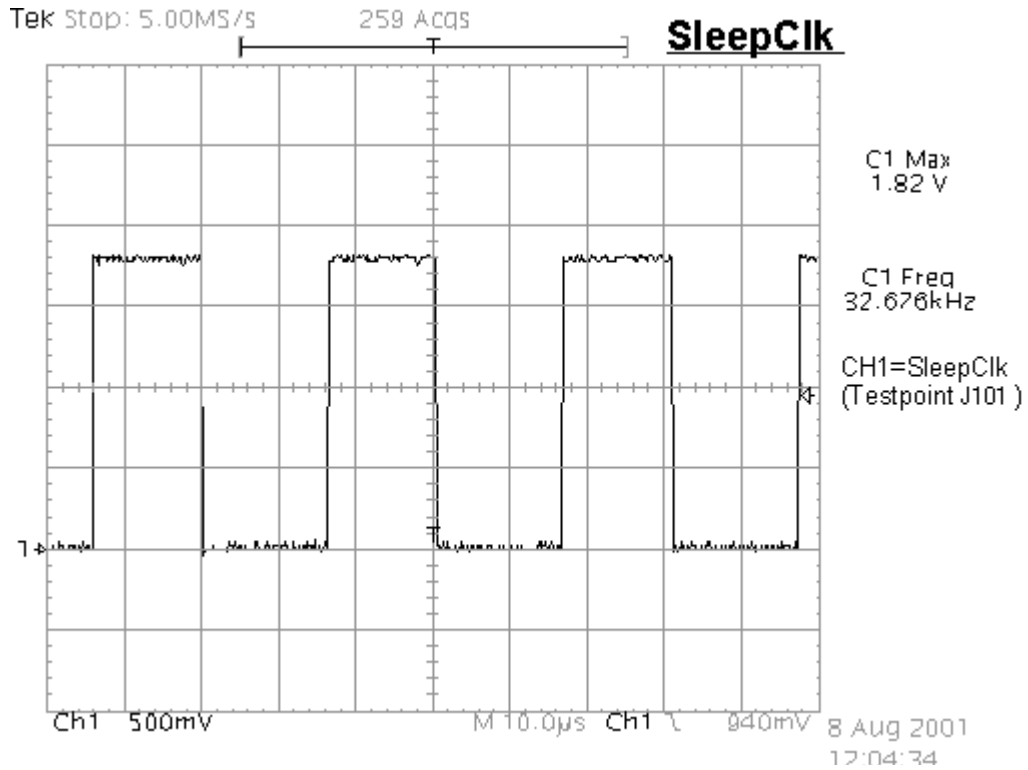

Charging checking

Use the BLB-2 battery and JBV-1 calibration set to test charging. (NOTE: power supply cannot be charged if it not has a current sinking capability.) When you are charging totally empty battery, remember that start-up charging might take a little bit longer time than normal. During this time display is blank.

If charger is not NMP approved type and its current and voltage is not within NMP charger window then software does not start charging and there is "NOT CHARGING" on the display. Voltage should be between 5.5V - 9.3V and current between 200mA – 850mA

Remove and reconnect battery and charger few times before you start to measure device. This check ensures that the fault really exists.

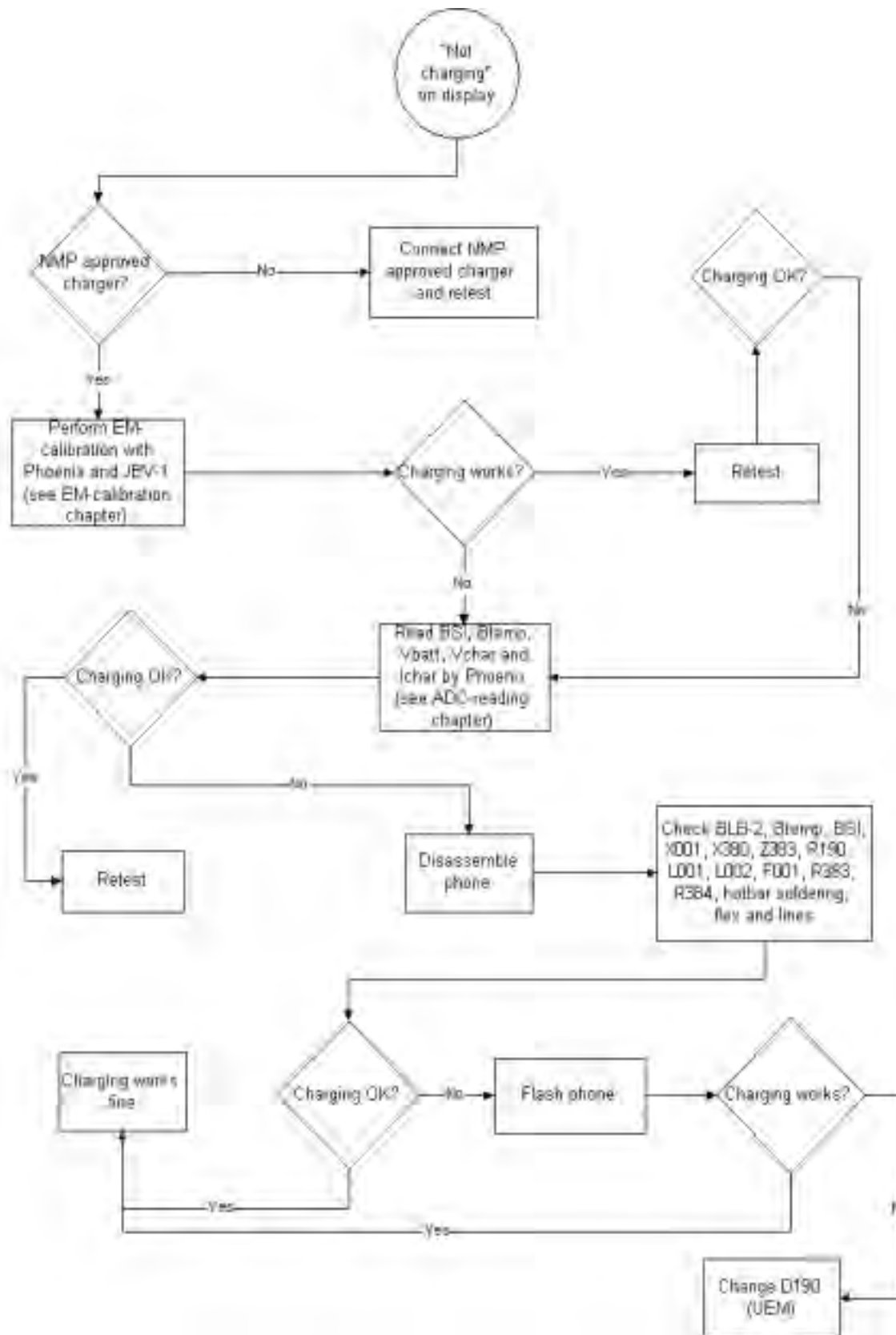

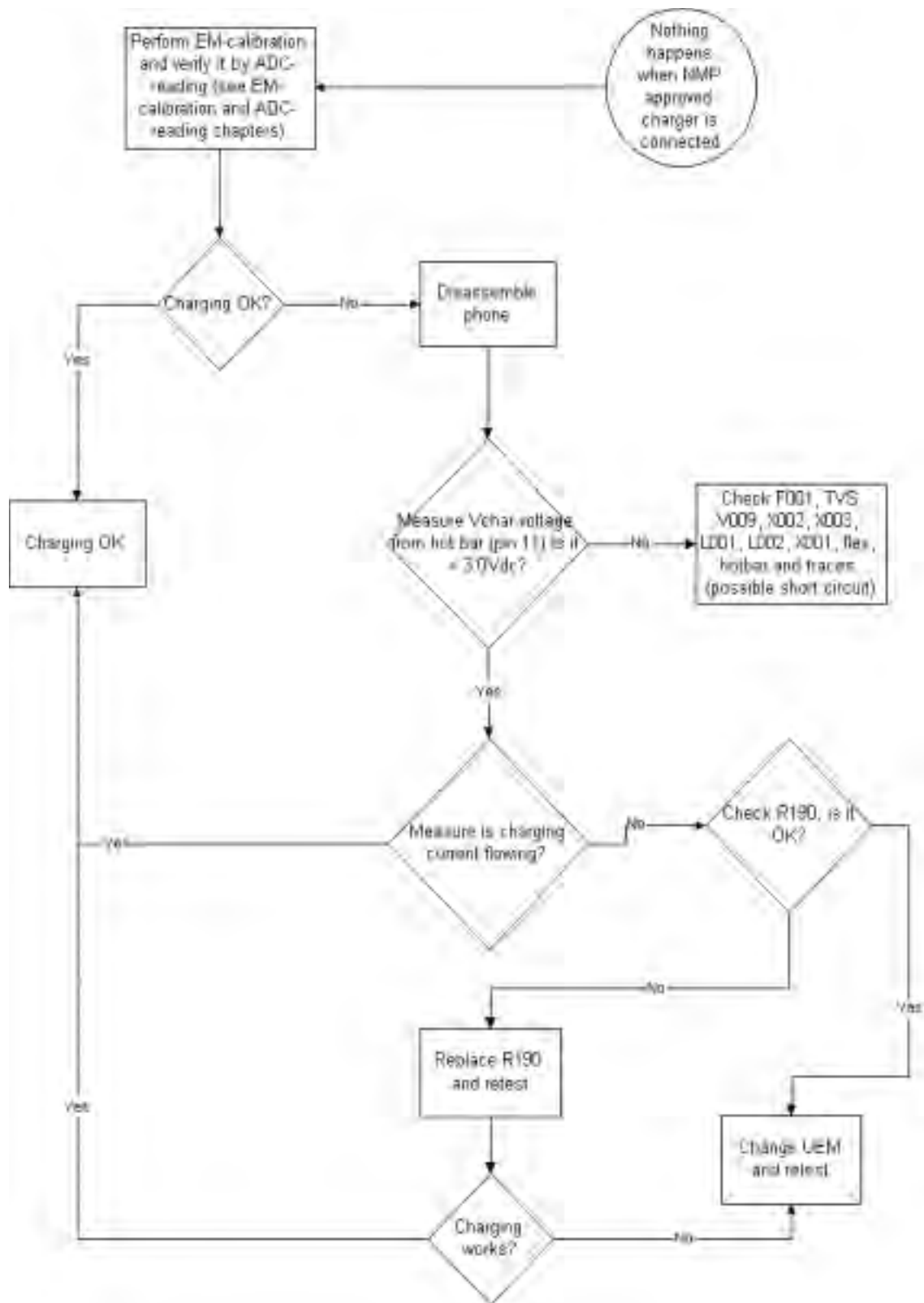

Energy management calibration

During energy management calibration A/D-converter, BSI, Btemp, Battery voltage, Charger voltage and Charger current are calibrated. **For detailed information and instructions see EM-calibration instructions in service manual.**

Troubleshooting tips:

ADC-offset over limits:

Inspect BSI line, connectors (hotbar and board to board connector) and components in it (Varistor R008, EMI-filter Z383, Pull-up resistor R384). If these are OK, change UEM.

BSI Gain over limits:

Inspect BSI line, connectors (hotbar and board to board connector) and components in it (Varistor R008, Capacitor C002, EMI-filter Z383, Pull-up resistor R384). If these are OK, change UEM.

Btemp Gain over limits:

Inspect Btemp line, connectors (hotbar and board to board connector) and components in it (Varistor R006, Capacitor C010, EMI-filter Z383, Pull-up resistor R383). If these are OK, change UEM.

Vbatt offset and Gain:

Inspect Vbatt lines and component in it.

Vchar over limits:

Inspect components which are connected Vchar line: Filtering capacitors C005, C006, C011, TVS V009, L001 and Fuse F001. If those are OK, Change UEM

Ichar over limits:

Inspect components which are connected at Vchar line: Filtering capacitors C005, C006, C011, TVS V009, L001 and Fuse F001. If those are OK, First change current sense resistor (R190), if calibration is not still successful change UEM.

Calibration can be checked using ADC-readings. Known voltages, currents and resistances are fed and read by ADC-readings, read values and known values can be compared.

ADC-reading

Divided and scaled battery voltage, Charger voltage, Charger current, BSI and Btemp values can be read by this tool. Read values few times before you can be sure that results are accurate.

Figure 4: ADC-readings view

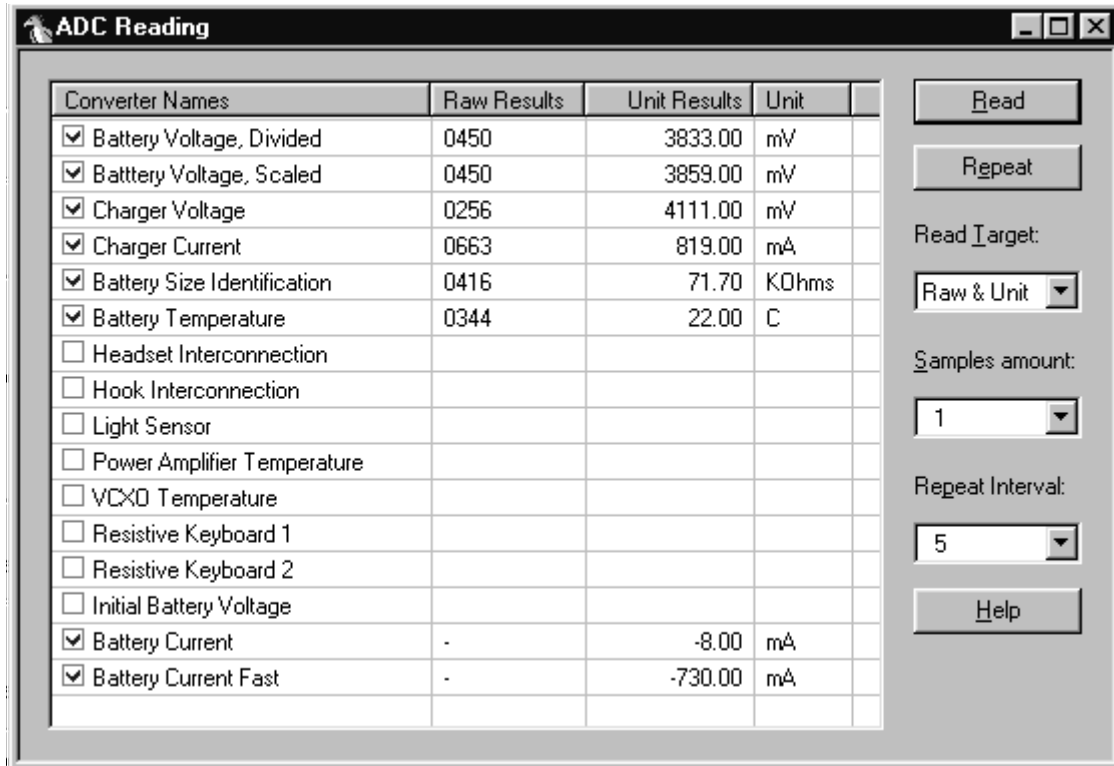

Note:: If Vbatt Scaled and Divided unit results are different default calibration values are used. In this case perform EM-calibration to get full performance of phone.

Maximum tolerances are:

Reading	Check point	Tolerance
Vbatt SCAL_	4.2V	± 25mV
Vchar	8.4V	± 40mV
Ichar	500mA	± 20mA
BSI	68k(BLB-2)	± 1.3kohm
Btemp	273K(47k)	± 5K

Backup battery

Symptom of backup battery fault is:

Real Time Clock loses the correct time during short main battery removal.

The same symptom can also be seen when the backup battery is empty. About 5 hours is needed to fully charge the backup battery in the device. NOTE: Backup battery is charged only the same time with main battery charging. Or when the device is LOCAL or TEST mode.

Always check that the backup battery visually for any leakage or any other visual defect.

Check that the backup battery is correctly mounted in the device before closing the cover.

- 1 Check with Phoenix is backup battery OK
- 2 Measure the voltage of backup battery
 - Normal operation when the voltage is > 2.0V
 - Fully charged when the voltage is about 3.2V (because of large internal impedance voltage won't stay above 3.0V a long time after charging is disabled)
- 3 Enable backup battery charging (start to charge main battery or boot device to LOCAL or TEST mode)
- 4 Measure voltage of backup battery during charging, It should arise if it is not 3.2V, yet.
- 5 When the voltage is over 2.0V for sure, check backup battery with Phoenix.
-> If not OK then D190 is faulty.
- 6 Ensure that the RTC is running.

IR interface

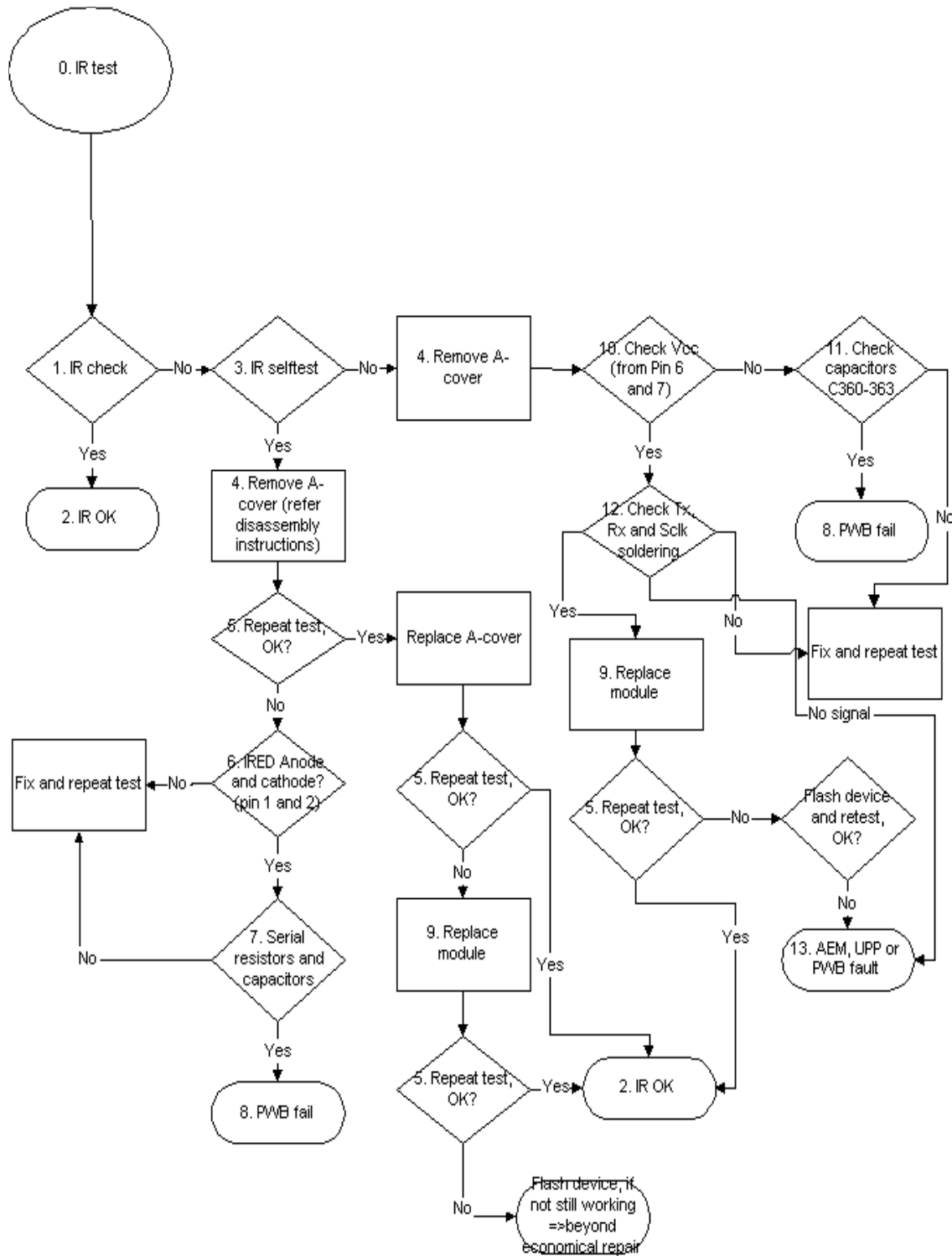

0. At this point it is supposed that problem is in HW
1. Send something to another phone or laptop
2. Everything is ok
3. Activate phones IrDA selftest
4. Take off phones A-cover
5. Start test again from the beginning, there might be more than one fault...
6. Check pin number 1 with voltage meter, first the pad and then the pin, there is supposed to be battery voltage
7. Make sure resistors R360 – R363 are connected and $< 10\text{ohm}$
8. Propably the fault is in PWB
9. Replace the IR module
10. Check Vcc, pins 6 and 7 in IR module, supposed to be connected to VMEMA, again first the pads and then the pins
11. Looking for shortcircuits in capacitors C360-C363
12. Check lines 3, 4 and 5 in IR module with oscilloscope during IR selftest, there should be series of pulses. Again check first pads and then pins.
13. Beyond economical repair

Sensors troubleshooting

This part of document is written to help troubleshooting for proximity sensor and ambient light sensor in NHL-2NA. Both of them are calibrated in production, in FINUI tester. AMS has possibility to calibrate proximity sensor at service points, ambient light sensor is repaired in Bochum.

This document is ment to be used only in troubleshooting and does not provide information on basic functionality of the systems. Basic operating principle can be found in chapter "System Module LG4 and Grip Module LS4", calibration instructions can be found in chapter "Service Software Instructions".

Proximity Detector

General notes

In the production proximity detector problems are best located from calibration results. Before starting troubleshooting with the help of this section, user should familiarize to the calibration instructions.

When the user brings the phone to the service point complaining that handsfree won't turn on, the problem can be either in the handsfree speaker circuitry, or in the proximity detector. This chapter gives instructions how to repair the problem in the proximity detector.

A good indicator that the proximity detector has caused disabling of the loudspeaker is, that the phone has switched the audio back to the earpiece. If the audio is not switched to the earpiece but also loudspeaker is not on, the problem is most likely in the handsfree circuitry.

When the problem is located on the proximity detector, the first thing to do is to check that proximity detector lenses are roughly OK. If any physical damage is found, replace lens module before proceeding to detailed troubleshooting.

If the problem is not this simple, the best way to look for the problem is to use PD calibration.

Remember that Proximity Detector has to be calibrated always when optocomponents or optics are replaced! Calibration also has to be done, if AEM ASIC is replaced or if calibration settings are lost from PMM.

Proximity Detector components

From now on Proximity Detector will be referred to as PD.

Main components of PD are lenses, emitter (IRED CL-200-IR, V334, 4860009), RSENSE 4R3 (R347), receiver (photodiode BPW34FS, V335, 486J830) and a control block, which is located on AEM ASIC (N226). Three external capacitors are part of the control block: 100n (C275) and 220p (C273 and C274).

Figure 5: Most important receiver and transmitter components

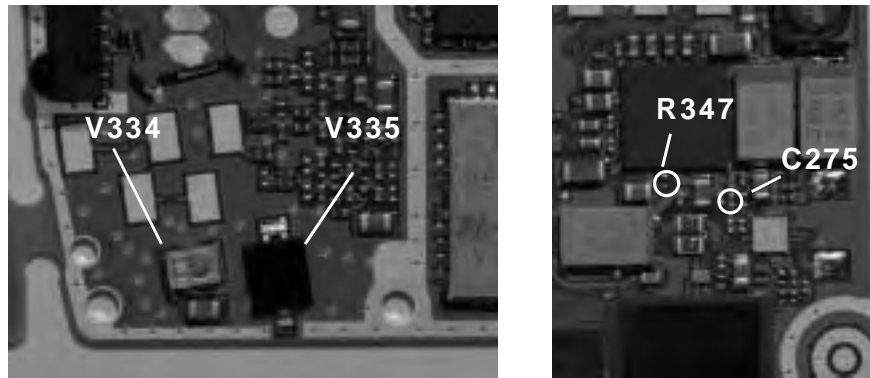

Handsfree shuts down automatically in sunshine

It is normal, if this behaviour occurs only in high ambient light conditions, e.g. direct sunlight, and no repair actions are needed. If this problem occurs also in low ambient light conditions (outdoors when the phone is not facing the sun), check that capacitors C273, C274 and C275 are placed correctly.

PD calibration

Proximity Sensor Calibration tool is shown in the Figure 4 Proximity Sensor Calibration tool. Parameters that are calibrated and saved to PMM are gain, detection threshold and fault detection threshold. When you start the calibration tool, the values in the PMM are shown in the left column. Second column shows start values used in calibration, they are defined by R&D. Calibration consists of two phases. First gain and detection threshold are calibrated. If this calibration is finished successfully, software starts fault threshold calibration; fault threshold cannot be calibrated alone. Offset value(s) are used to adjust the thresholds to compensate possible wearing of the PD. To help troubleshooting phone SW response is one of the 13 messages that are explained in the next chapter. Successful gain and detect threshold calibration tells that optoelectrical components are OK. Note! Values in this picture might change.

Figure 6: Proximity Sensor Calibration tool

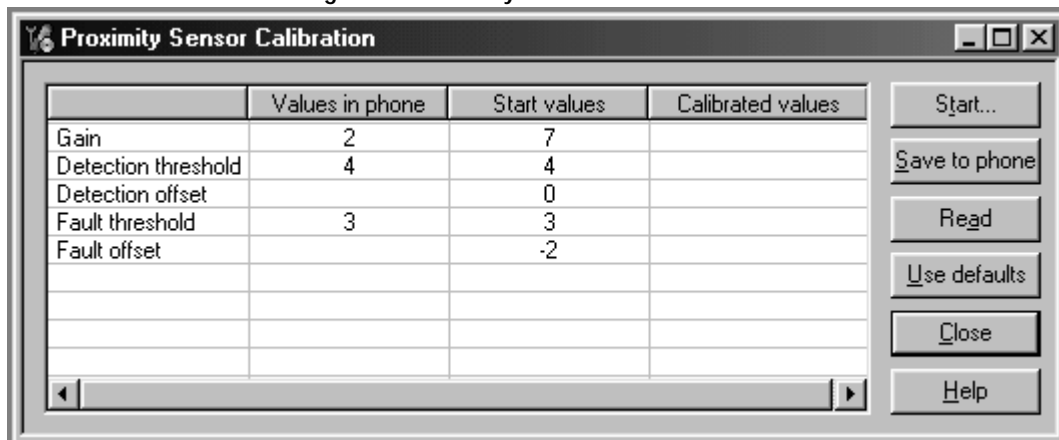

Troubleshooting with PD Calibration results

CALIB OK (0x00)

This is the response, when calibration is done successfully. Save calibration results to the phone.

START ILLEGAL PARAMETER (0x01)

Calibration starts with rough check for start values. Detection threshold, gain and fault detection threshold must be between 0 and 7; offset for both of them is from -7 to 7.

Default start parameters never fail to meet these limits. Check that correct limits are used in the calibration SW (PC or Phoenix) and try calibration again.

PXM GAIN INT FAIL (0x02)

This should be impossible. If, however, you manage to get this error, try calibration again.

DET TR FAIL (0x03)

An error has occurred during calibration. Try calibration again. If no result is obtained in three calibrations, replace proximity optics.

Another option is, that detection offset is too big for calibrated detection threshold. This isn't possible, if start values are correct. Use default start values.

OFFSET FAIL (0x05)

Selected offset could not be used with this calibration result. Check, that you have used correct default offset. Then replace the optics.

DET NOT DONE (0x06)

Fault calibration can be done only directly after detect calibration. If, for example, the phone was restarted between fault –and detect calibration, this error occurs. Repeat whole calibration.

COMBINATION FAIL (0x07) / W OFF FAIL (0x08)

Calibrated detection threshold, fault detection threshold and detection offset form a combination that is not allowed. Use default start values in calibration and check that proximity rubber is OK. If this does not help, replace optics.

FAULT INT FAIL (0x09)

This error occurs, if self-monitoring signal is too small to exceed any fault threshold (when offset is added). This error occurs also if there is a detection during fault threshold calibration.

Is proximity optics and proximity rubber OK (visual check)? If not, replace optics. Check calibration conditions and repeat calibration.

FAULT OVER LIMIT FAIL (0x10)

This error occurs in fault detection threshold calibration, if self-monitoring signal is higher than each fault detection threshold. There are two reasons, that could cause this failure:

Detection calibration is done without the calibration target or the target was too far from the phone.

Fault calibration was done with the calibration target.

Check calibration conditions and repeat calibration.

GAIN MAX LIMIT FAIL (0x0B)

Gain value has reached its maximum limit, and there are no detections. This means, that path from tx to rx is broken. Most probable is, that the failure is on the LG4. Figure 5 GAIN MAX LIMIT FAIL troubleshooting presents troubleshooting diagram for this failure.

Figure 7: GAIN MAX LIMIT FAIL troubleshooting

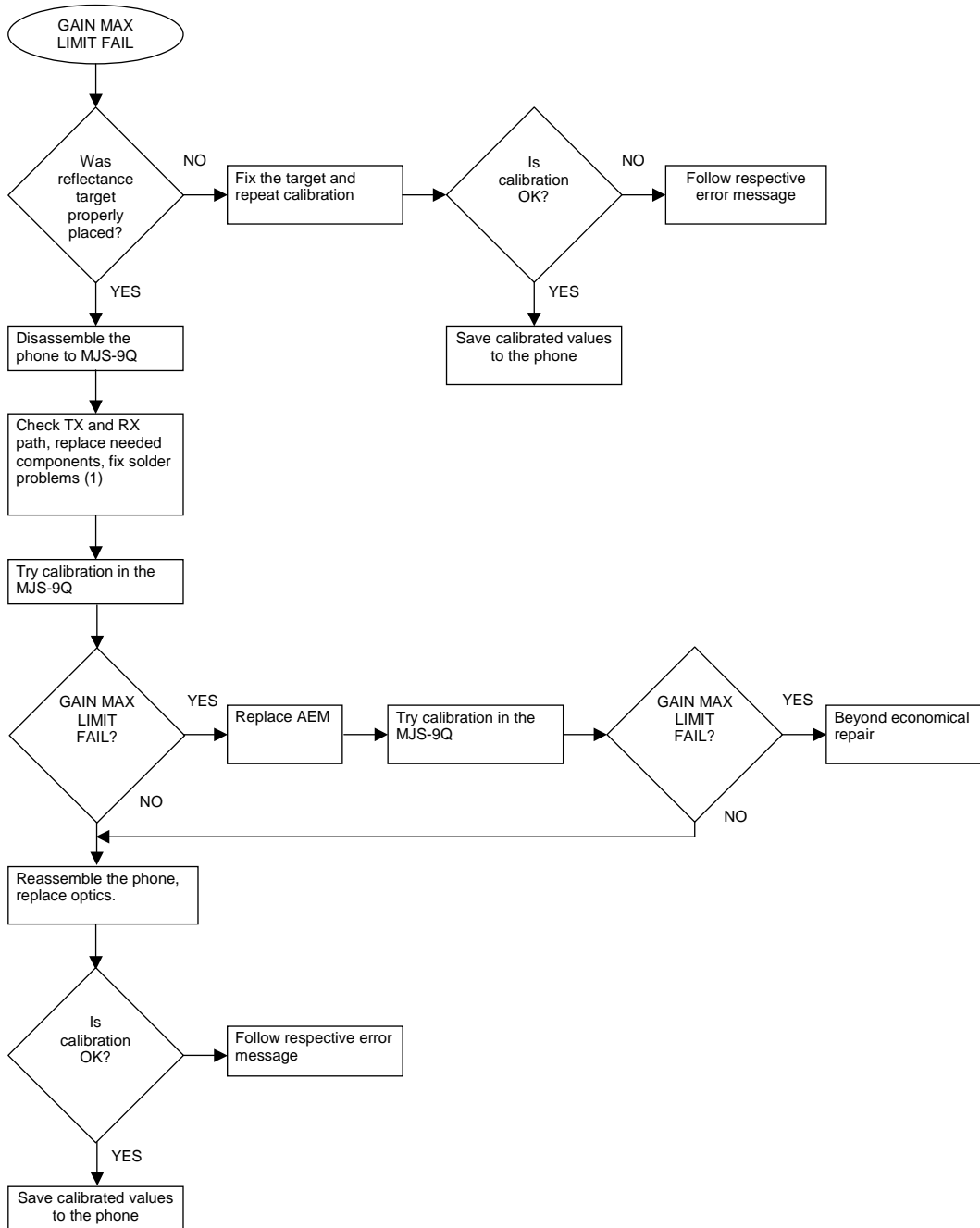

- 1 PD TX line: RSENSE R347 is connected to GND and IRED V334 to Vbatt
RX line: photodiode V335 is connected to GND. See figure 5.
- 2 If there is no obvious fault, replace first V335, then V334. Try calibration in the MJS-9Q in between.

GAIN MIN LIMIT FAIL (0x0C)

There is a detection at each gain. IRED, RSENSE and photodiode are OK. Possible reasons are shortcut in RSENSE, missing optical insulator or wrong start values in calibration.

Figure 8: GAIN MIN LIMIT FAIL troubleshooting

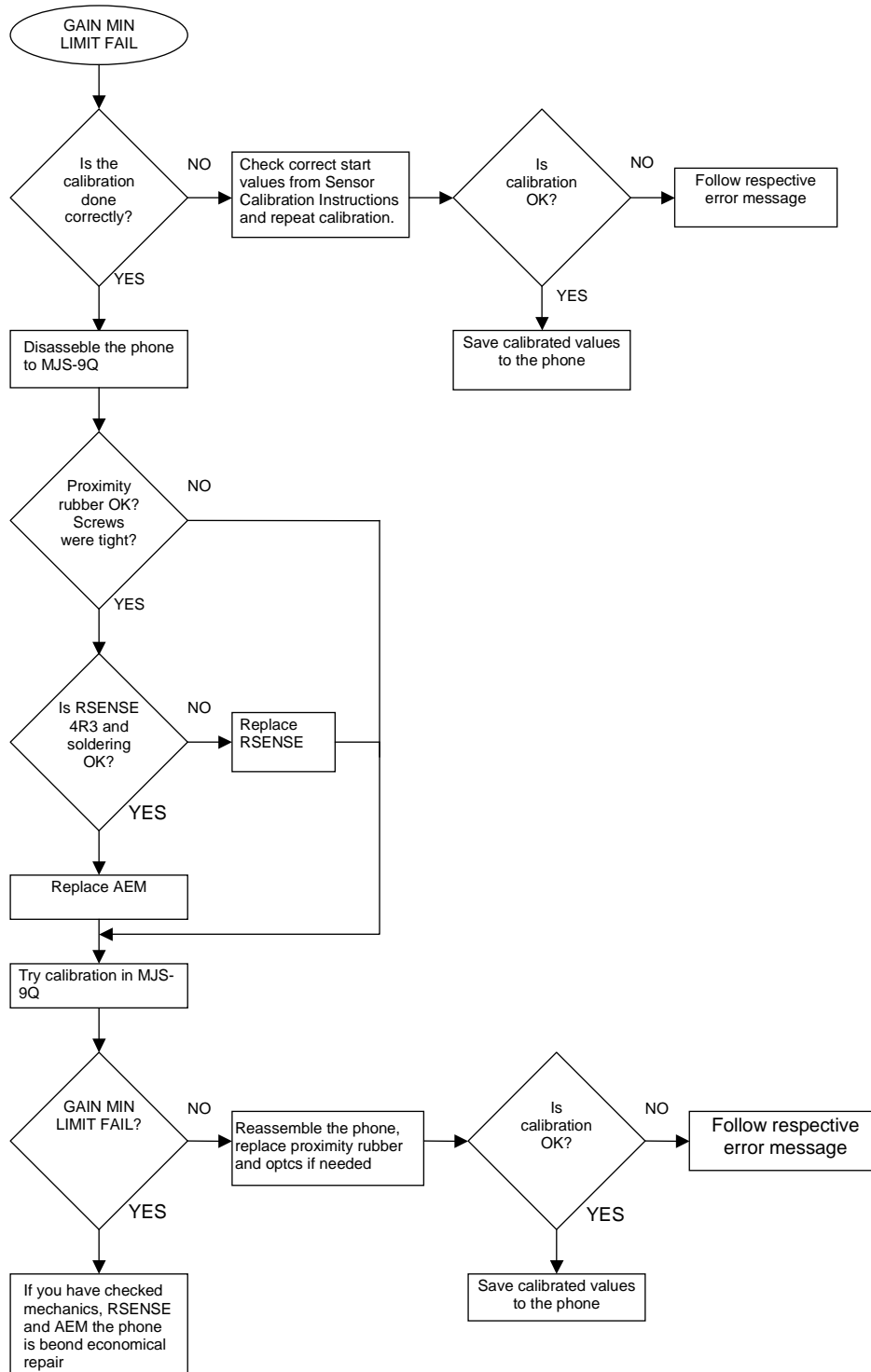

Ambient Light Detector

General Notes

Ambient light sensor problems can be found during the calibration process or as problems with the display backlight and grip LEDs. The problem can also be in the NTC-resistor, which is used for temperature compensation of the ambient light detector. Before starting troubleshooting according to these instructions, it must be ensured that the problem really is in the ambient light detector. Other possibility is e.g. UI-module or backlight powering itself. This can be checked easily, because light sensor can be turned off.

Calibration of the Ambient Light Detector is needed always, when the phototransistor is replaced.

Calibration system is described in chapter "Service Software Instructions".

Figure 9: Ambient light detector calibration tool

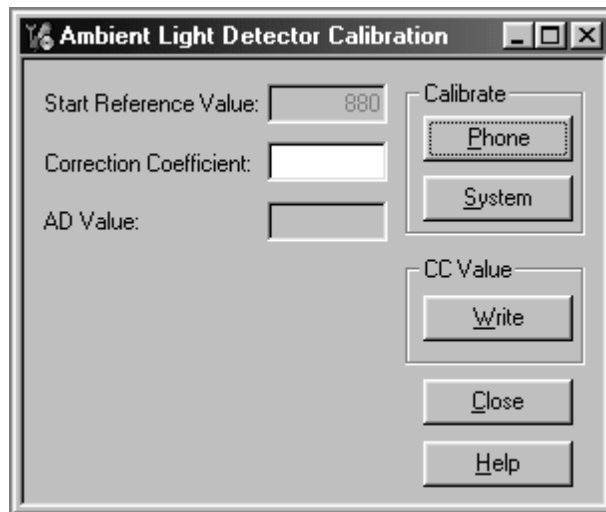

Ambient Light Detector

From now on the Ambient Light Detector will be referred to as ALD.

Main components of the ALD are phototransistor SFH3410 (V130, 4864901), pull-up resistor 22k Ω (R131) and UEM (D190) ADC. There is also an NTC-resistor 47k Ω (R132, 1820037), which is used for temperature compensation. Temperature compensation is done by SW.

Figure 10: Ambient Light Sensor components

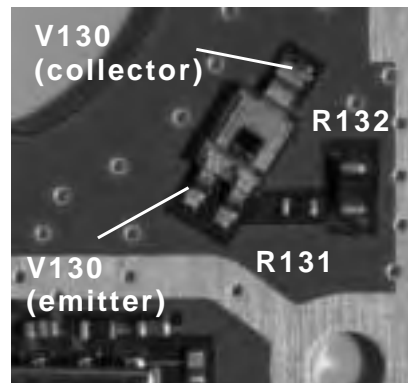

Problems from the user point of view

"The sensor doesn't control backlights of the phone"

Figure 11: ALD troubleshooting 1

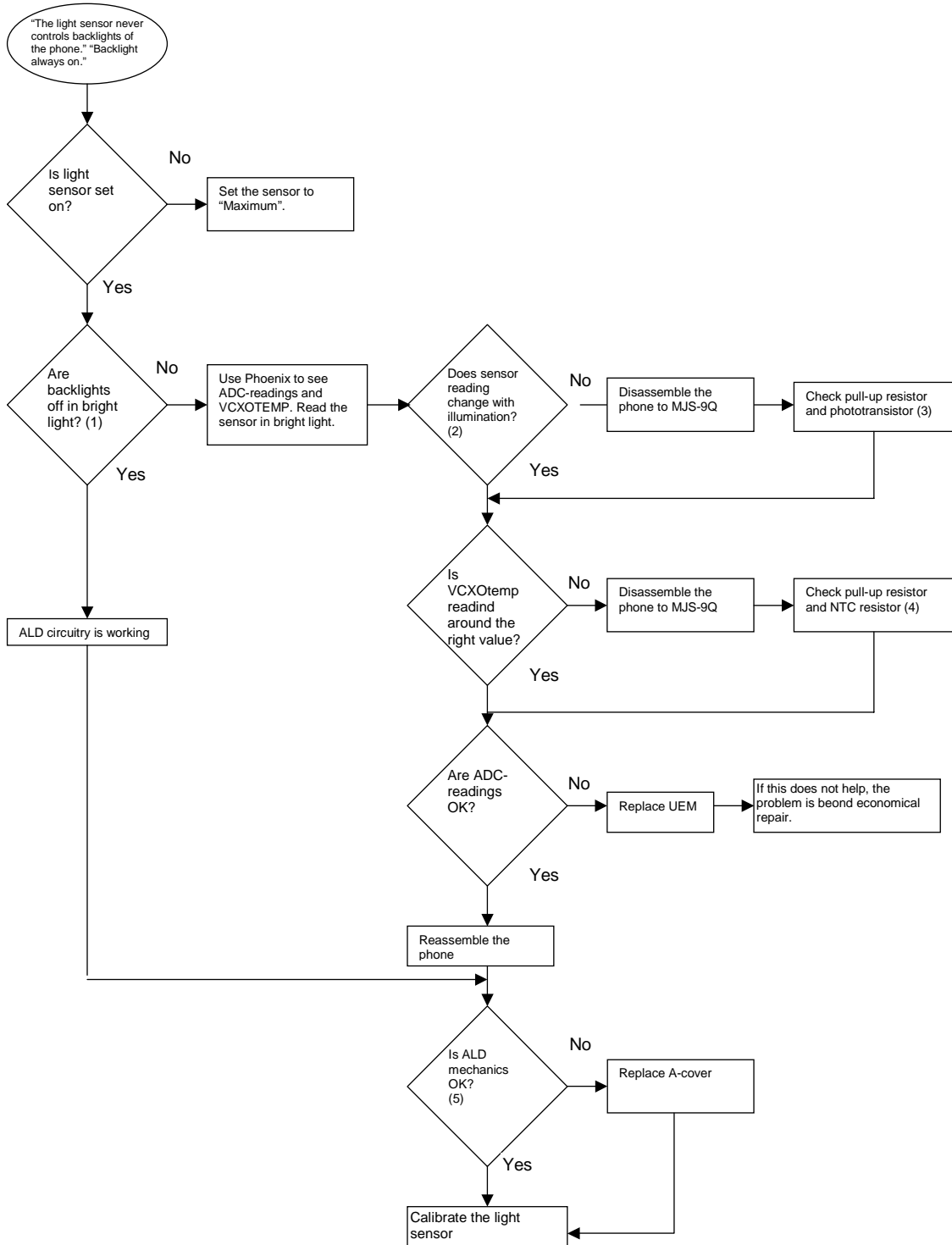

- 1 Set light sensor sensitivity to minimum. Illuminate sensor from close range with very bright light.
- 2 Sensor ADC-reading should be <500 in bright light and in total darkness >900.
- 3 Check that resistance between sensor collector and VFLASH1 is 22k Ω (R131). Check that resistance between collector and emitter of the ambient light sensor changes, when illumination on the sensor (from ~5k Ω in high illuminance to ~500k Ω in total darkness) (V130). If phototransistor has to be replaced, the detector has to be calibrated. Calibration can be done only with TDS-11 light source.
- 4 NTC (R132) resistance at room temperature is ~47k Ω .
- 5 Check following points: is opening on the black paint in the A-cover covered; is light guide (integrated in the A-cover) broken?

"Backlights are never ON"

Figure 12: ALD troubleshooting 2

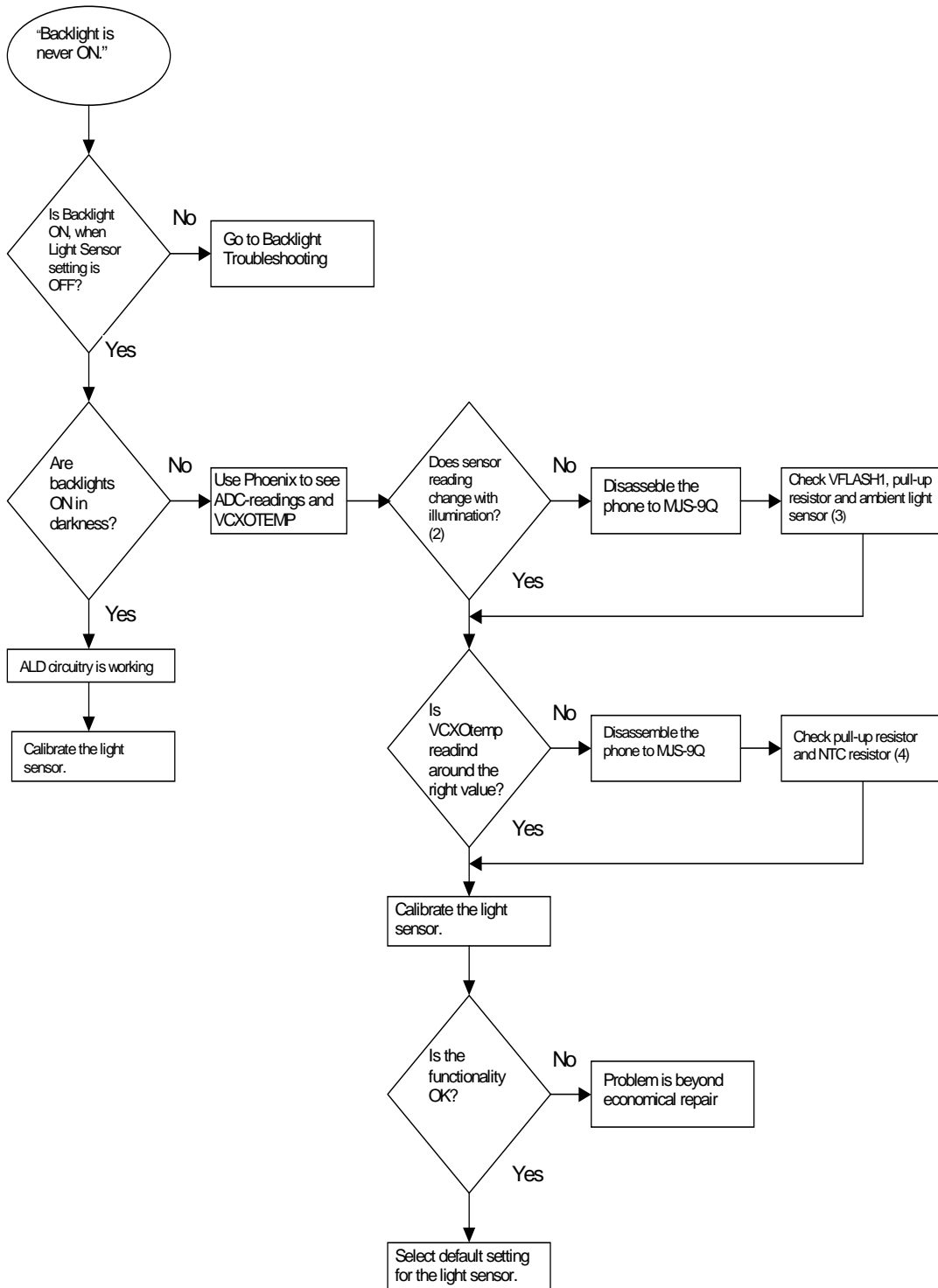

- 1 Set light sensor sensitivity to "minimum". Cover ALD window for example with a hand.
- 2 Sensor ADC-reading should be <500 in bright light and in total darkness >900.
- 3 Vflash1, measured at pull-up resistor pin, should be 2.78V. Check that resistor R131 is placed, and it's resistance is 22k Ω . Check that resistance between collector and emitter of the ambient light sensor changes, when illumination on the sensor (from ~5k Ω in high illuminance to ~500k Ω in total darkness). If phototransistor has to be replaced, the detector has to be calibrated. Calibration can be done only with TDS-11 light source.
- 4 NTC (R132) resistance at room temperature is ~47k Ω .

SIM card

The whole SIM interface locates in two chips UPP_WD2 and UEM. UEM contains the SIM interface logic level shifting. UPP provides SIMClk through UEM to the SIM. SIM interface supports both 3 V and 1.8 V SIMs. There is an EMI component on Ig4 between the sim card and UEM which isn't shown in the below picture. One pullup resistor is also on board at simdata line, which isn't shown in the picture.

Figure 13: UPP WD2 & UEM SIM connections

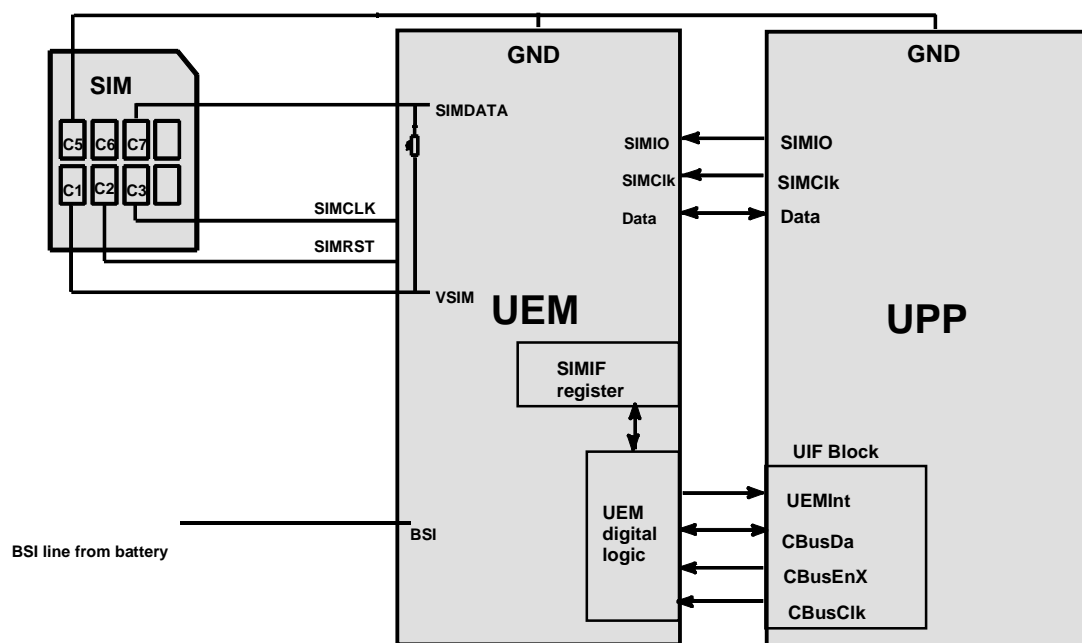

The SIM-power up/down sequence is generated in the UEM. This means that the UEM generates the RST signal to the SIM. Also the SIMCardDet signal is connected to UEM.

First the SW attempts to power up the SIM with 1.8 V. If this does not succeed power up is repeated with VSIM switched to 3 V.

The data communication between the card and the phone is asynchronous half duplex. The clock supplied to the card is in GSM system 1.083 MHz or 3.25 MHz. The data baudrate is SIM card clock frequency divided by 372 (by default), 64, 32 or 16.

Figure 14: SIM Power Up.

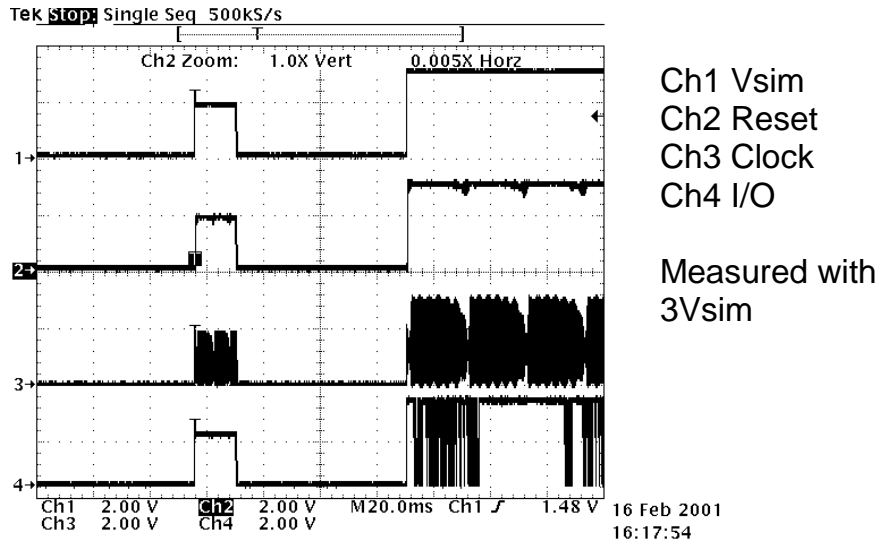
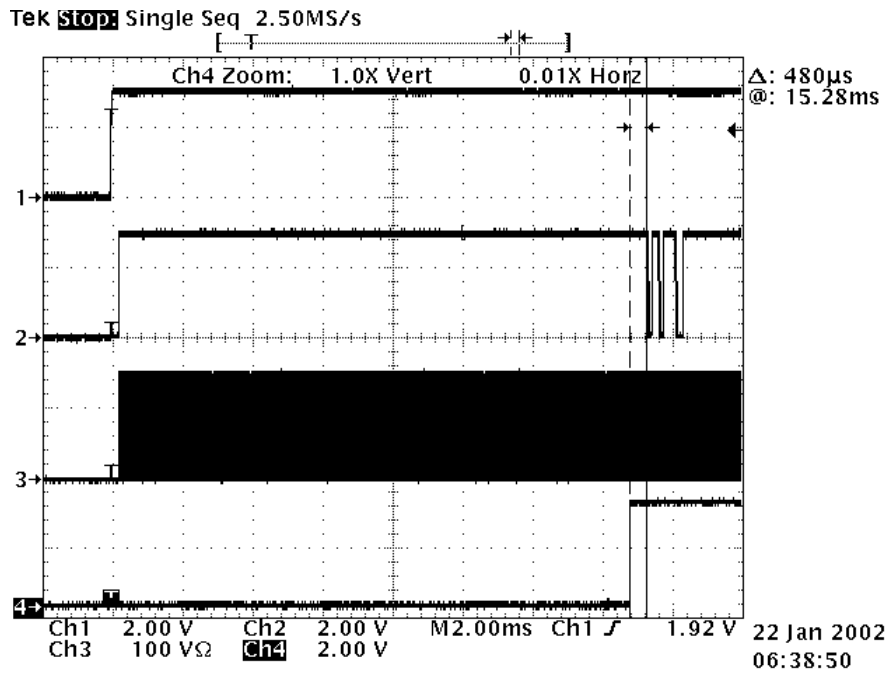
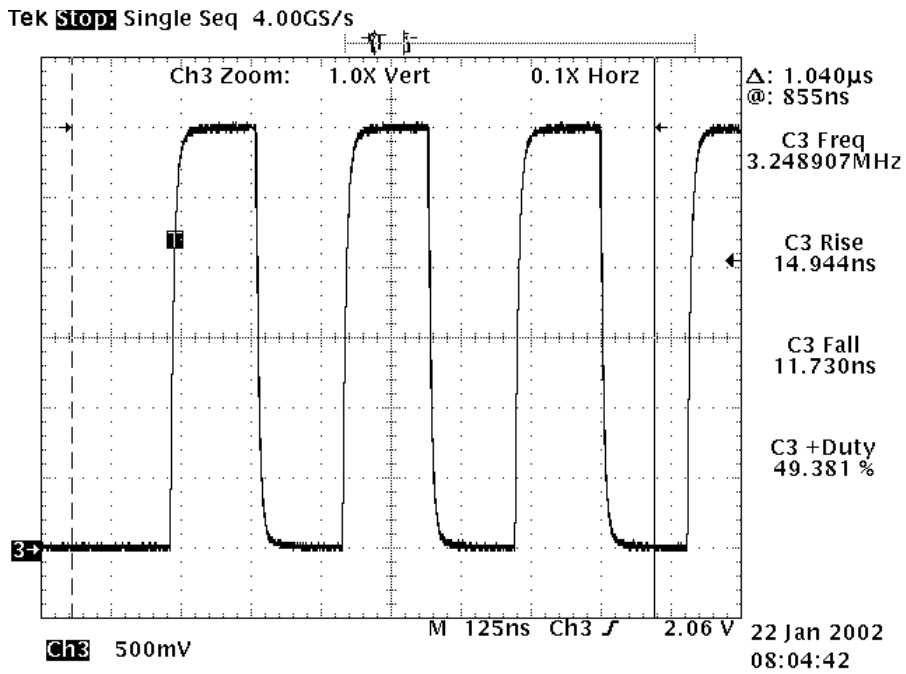

Figure 15: SIM answer to reset



- Ch1 Vsim
- Ch2 sim_data
- Ch3 sim_clk
- Ch4 sim_reset

Figure 16: SIM Clk 3.25MHz



"Insert SIM Card" in device display although card is inserted

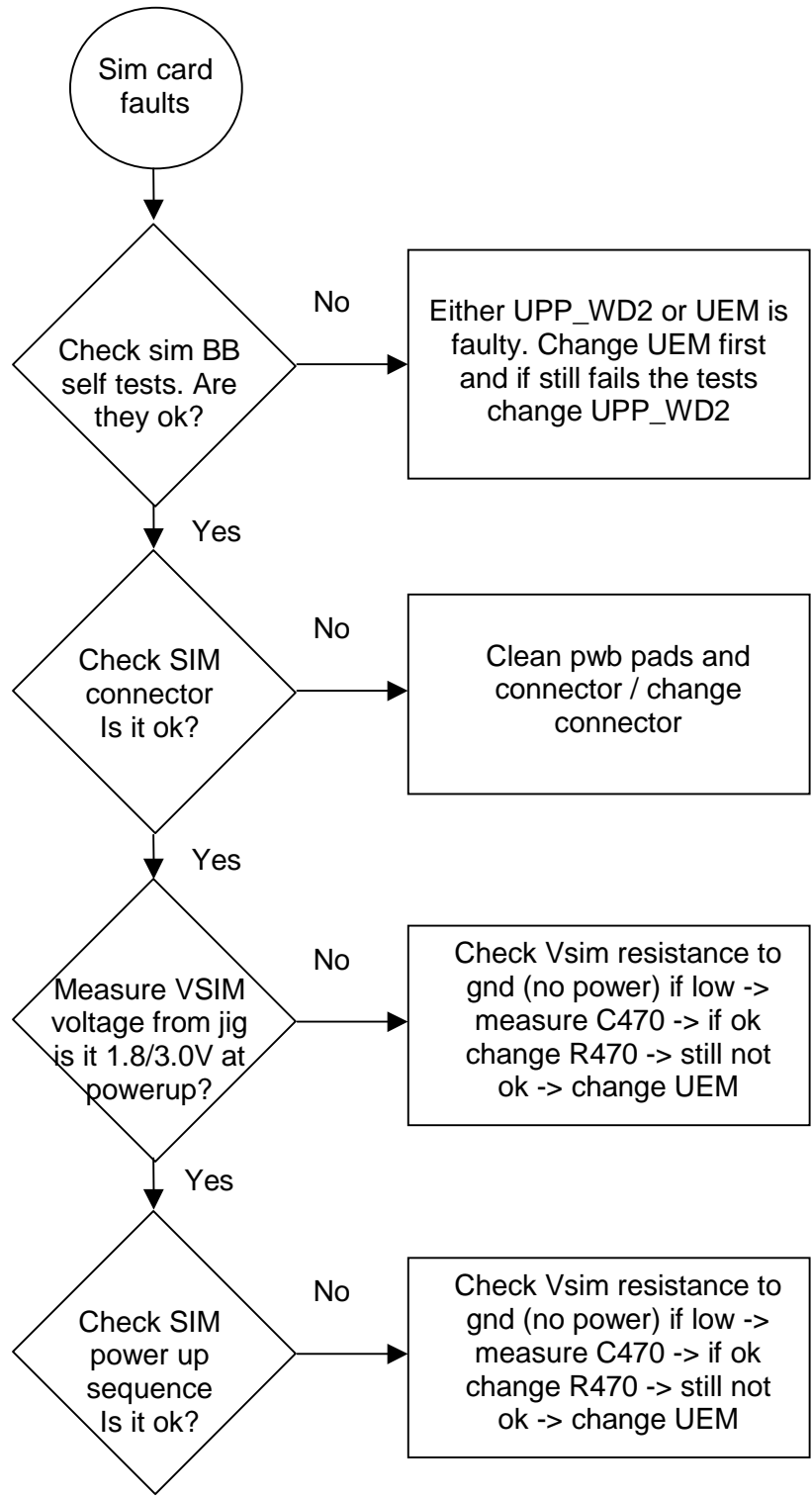

Audio

Microphone

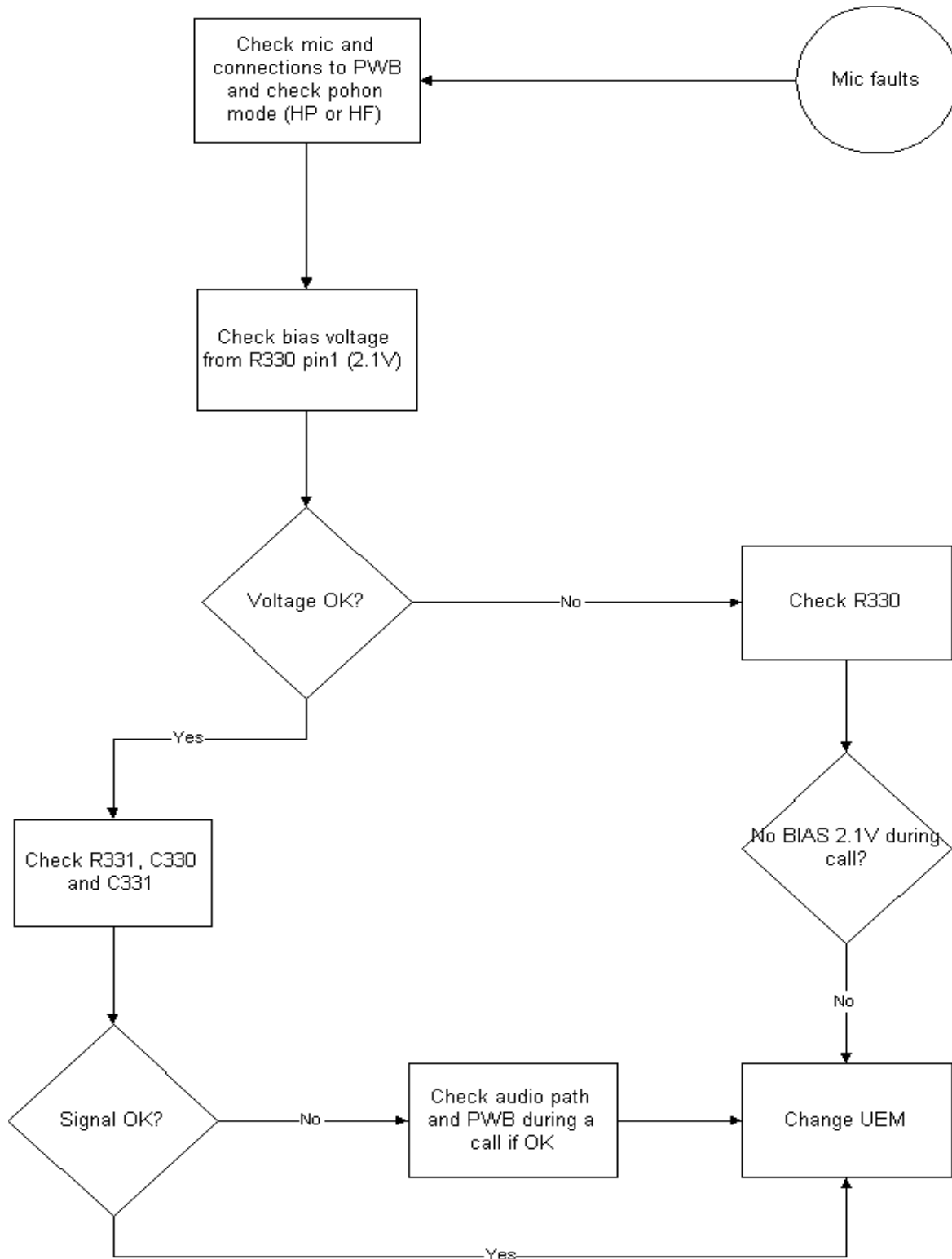

Earpiece

Check that holes are not covered.

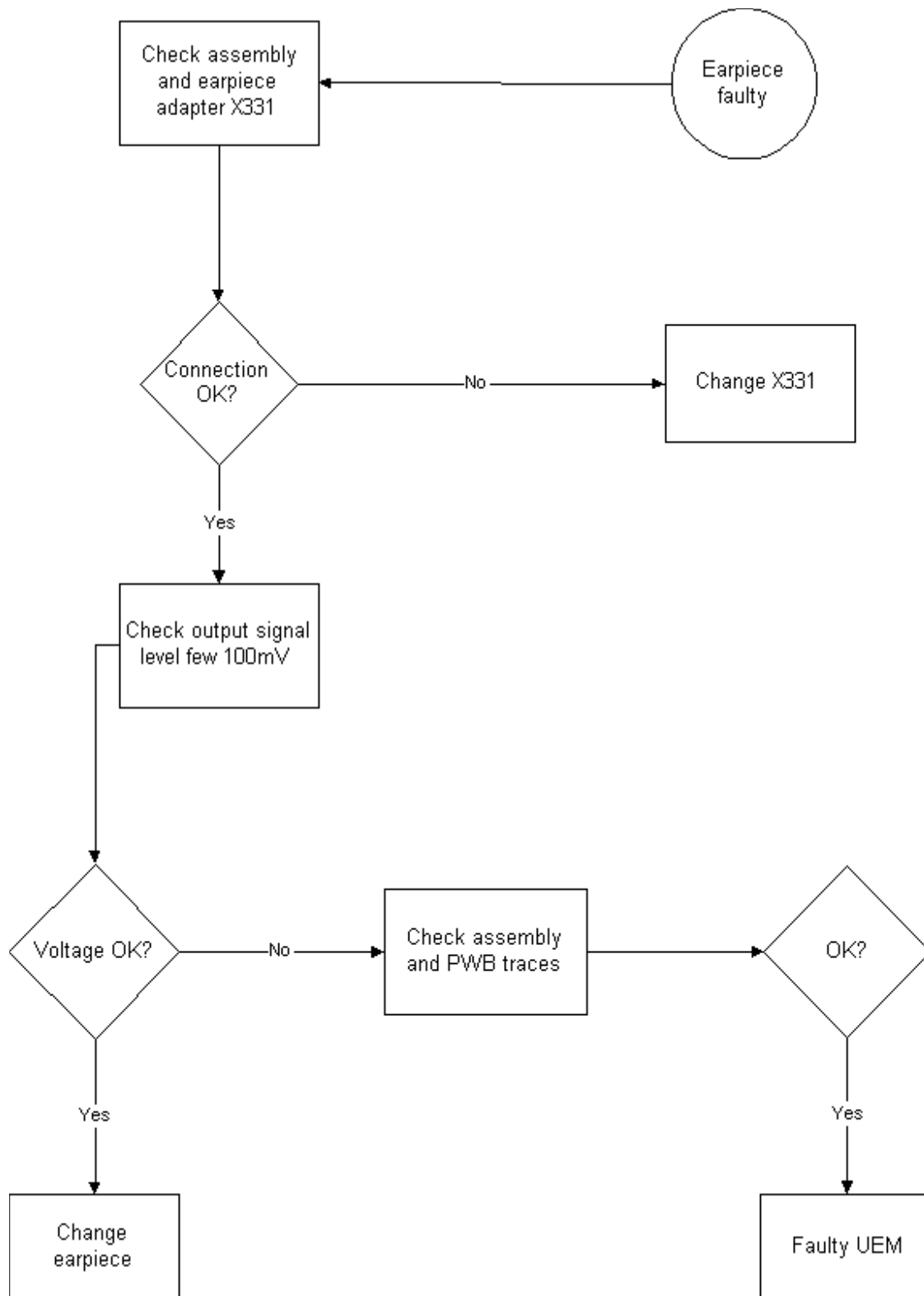

IHF

In the case of IHF fault the reason can be found from integrated hands free itself or proximity sensor. Proximity sensor disables IHF if phone is too near some object. It is possible if the proximity sensor is faulty IHF can not be enabled even if it is working fine.

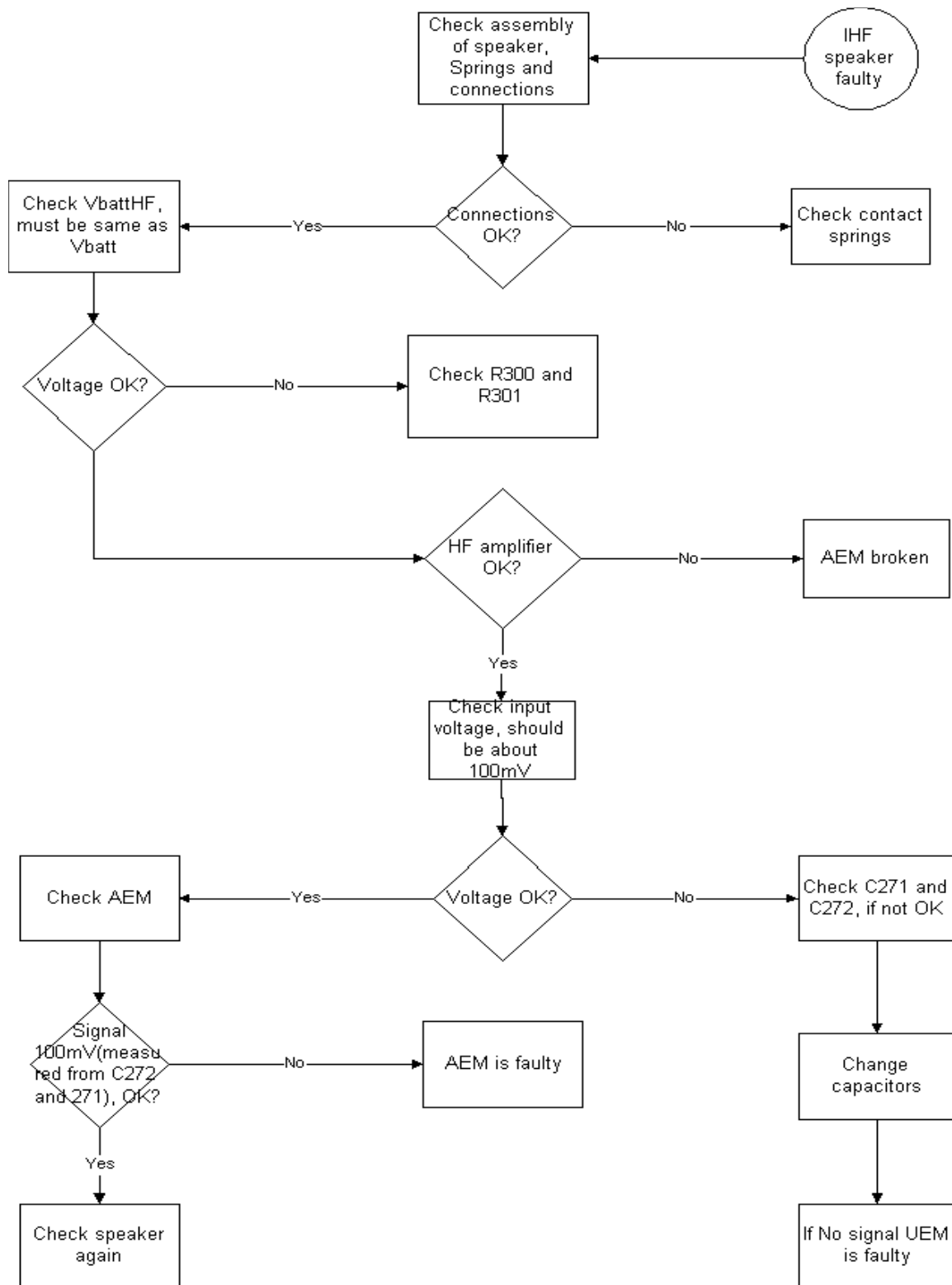

Accessory detection troubleshooting

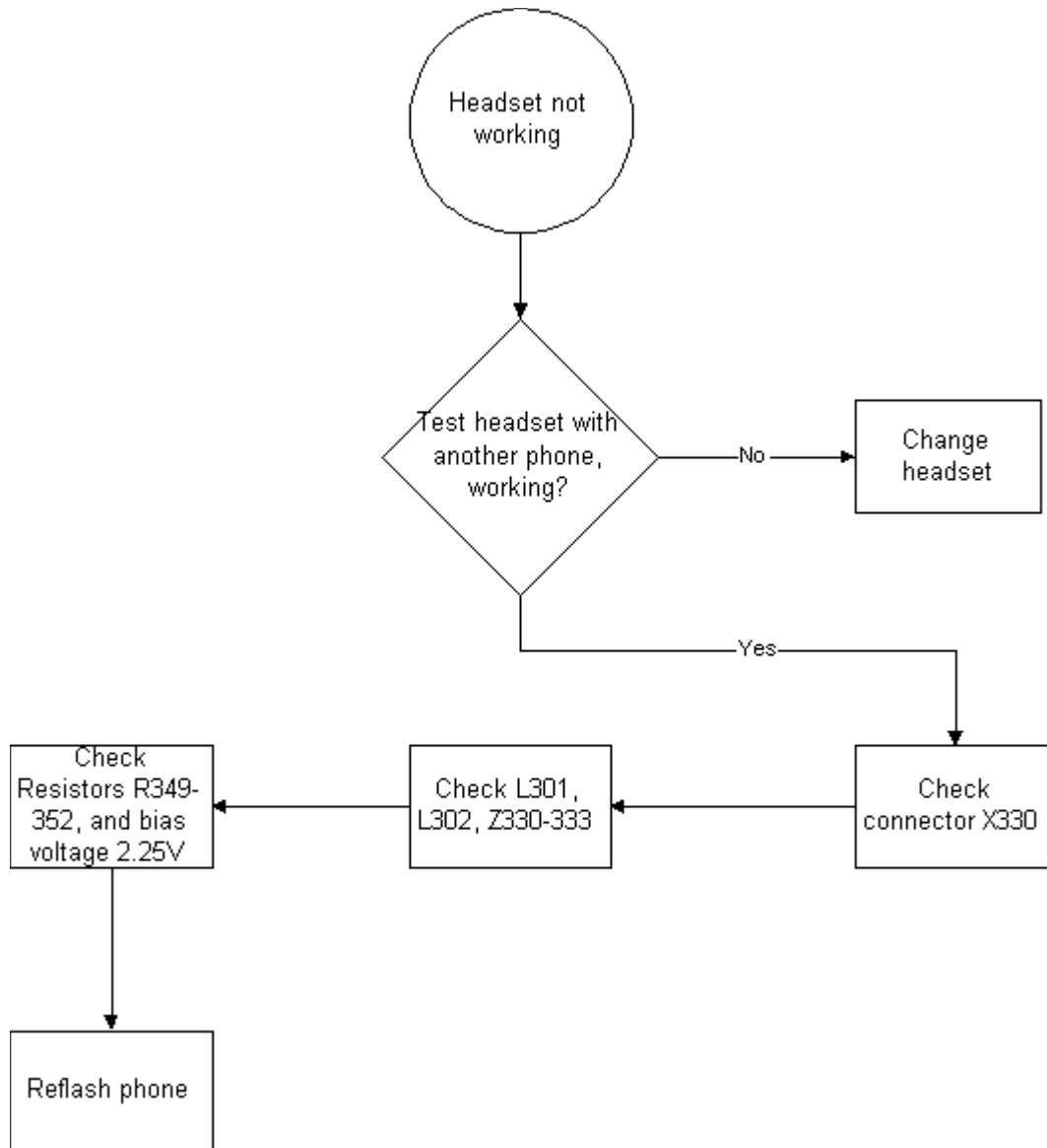

Memory troubleshooting

Most memory related errors are found through flashing the device, flashing the device is therefore recommended before any of the steps described in this chapter. Check flashing troubleshooting section first.

There are however a few memory related errors that cannot be found through flashing.

- SDRAM partially damaged
This can mean that the sdram component itself is partially damaged and all the memory locations cannot be successfully accessed or there is a soldering problem somewhere either under UPP or sdram.

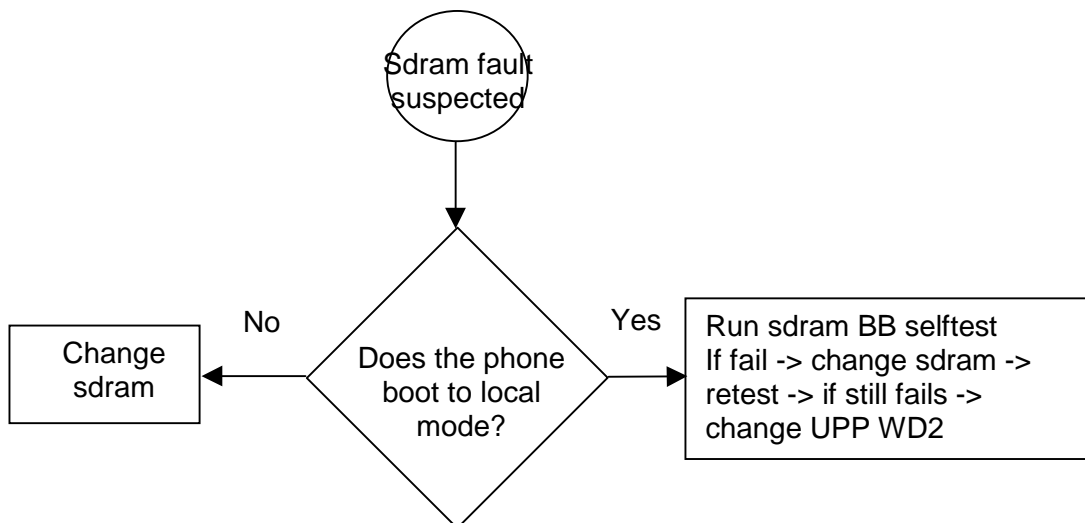

- flash1 (D310) is partially/totally damaged
During flashing the manufacturer, device and revision id's are read, but flashing is done based on id's of the flash0 (D311). This means that one cannot see any error messages displayed on Phoenix window during flashing if flash1 is failing. Id's are however displayed on the Phoenix window and successful read of flash1 id's can be checked from there. One good way to test flash1 functionality is to format it(from Phoenix).

Baseband serial interface troubleshooting

CBUS

CBUS is a three wire serial interface between main baseband components. The bus consists of data, clock and bus_enable signals. In NHL-2NA the bus is connected from UPP WD2 to AEM, UEM and the BT module. UPP_WD2 takes care of controlling the traffic on the bus.

If the interface is faulty from the UPP WD2's end the phone will not boot properly as powering configurations do not work. Traffic on the bus can be monitored from three pins on the BT module. Pins are shown below.

Figure 17: CBUS measuring points

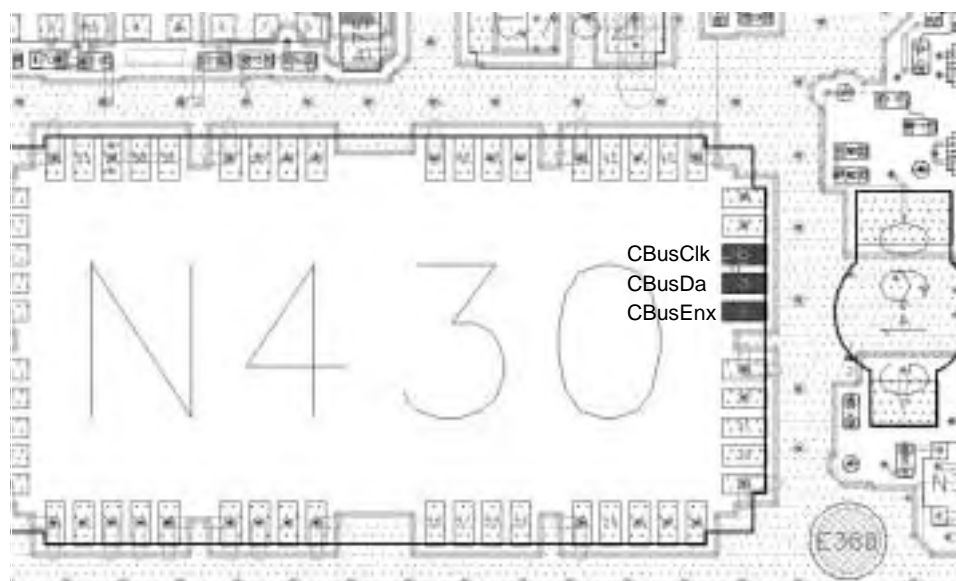

In the pictures below CBUS traffic at bootup is shown. CbusEnx is connected to Ch1, Cbus Da to Ch2 and CbusClk to Ch3. The lower is just a more detailed picture of a write command (to AEM).

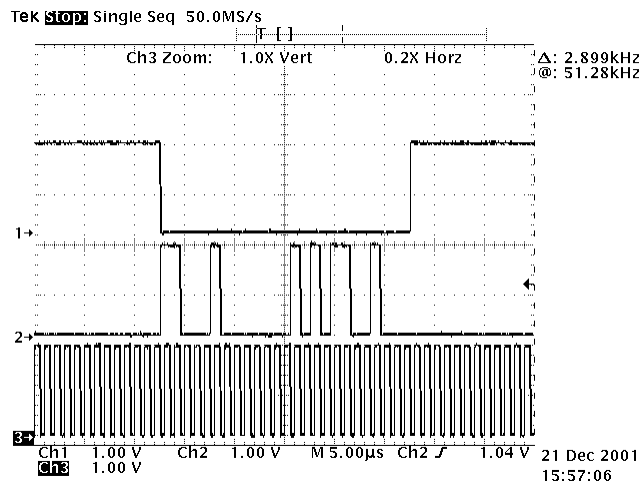
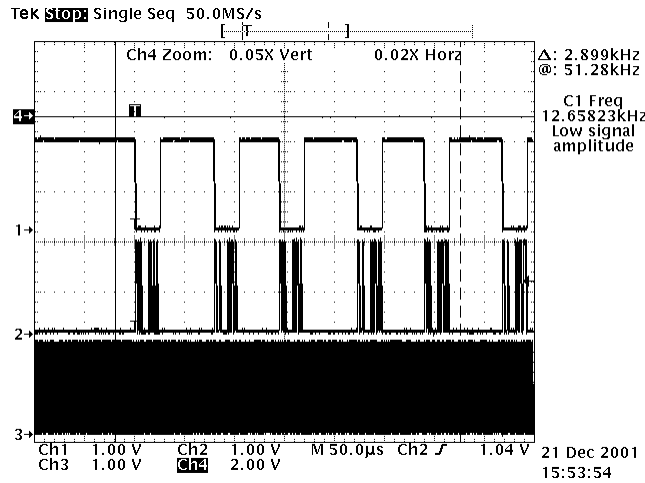

However, if you are able to get the phone to boot up and can reach Phoenix BB self tests it is possible to test the functionality of each component attached to Cbus. Use:

- ST_AEM_CBUS_IF_TEST to test AEM Cbus interface
- ST_UEM_CBUS_IF_TEST to test UEM Cbus interface
- ST_LPRF_IF_TEST to test Bluetooth Cbus interface

If an error is found testing any of the above components you should replace or re-solder the failing component.

FBUS

FBUS is a two wire RX and TX interface between UPP and flash/test interface. The bus goes through UEM which adjusts the voltage levels to suit UPP_WD2. The interface voltage level on the phone flash/test pad pattern is 2.78V and on the UPP WD2 end it is 1.8V. The functionality of this interface should not affect the device boot into NORMAL, LOCAL nor TEST modes. Phoenix tests can be performed through MBUS interface in the case of a failure in FBUS interface. Flashing is not possible if there is a problem in FBUS interface.

MBUS

MBUS is a two wire RX and TX interface between UPP and UEM. From UEM the interface continues to flash/test interface as a one wire interface. UEM adjusts the voltage levels. The interface voltage level on the phone flash/test pad pattern is 2.78V and on the UPP WD2 end it is 1.8V. MBUS traffic between UPP WD2 and UEM can be tested with PHOENIX (ST_MBUS_RX_TX_LOOP_TEST). Flashing is not possible if there is a problem in MBUS.

Hall sensor troubleshooting

There might be two kind of malfunction concerning Hall sensor; The out put of the Hall sensor keeps to high or low regardless the position of the magnet.

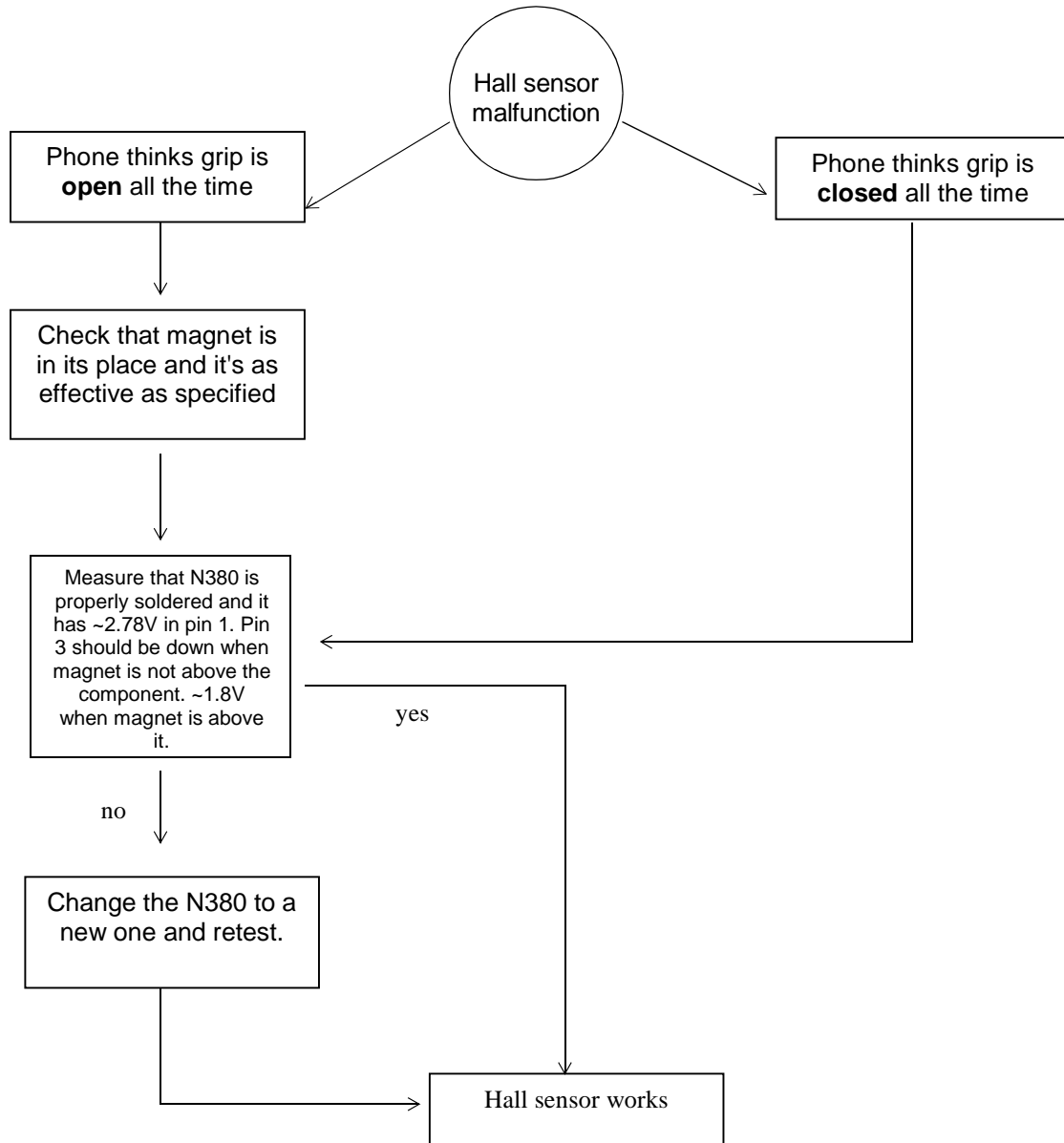

Display backlights troubleshooting

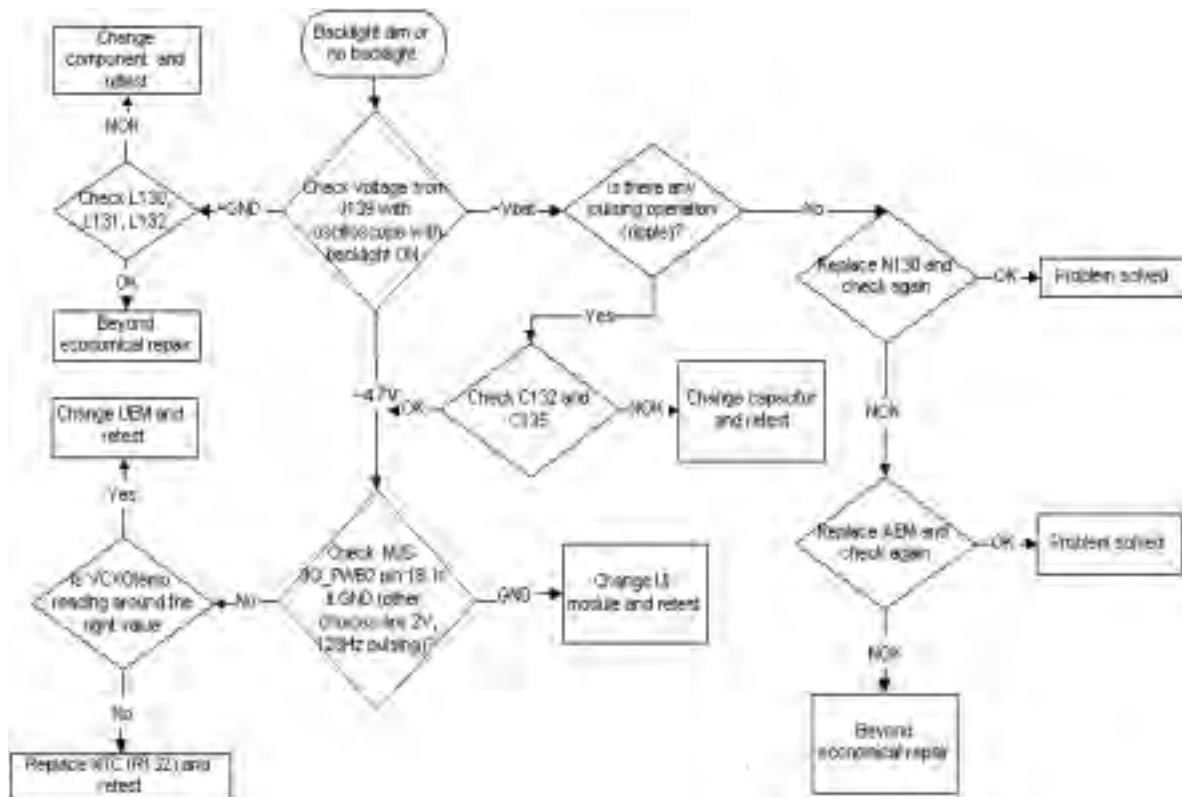

Bluetooth troubleshooting

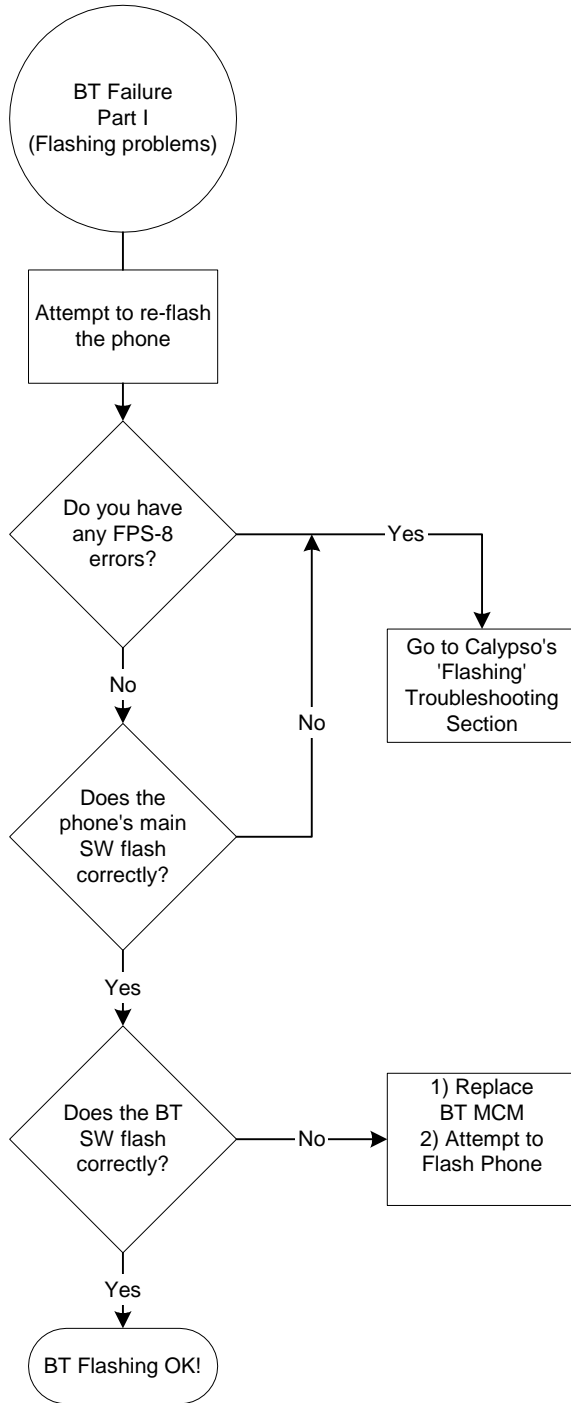

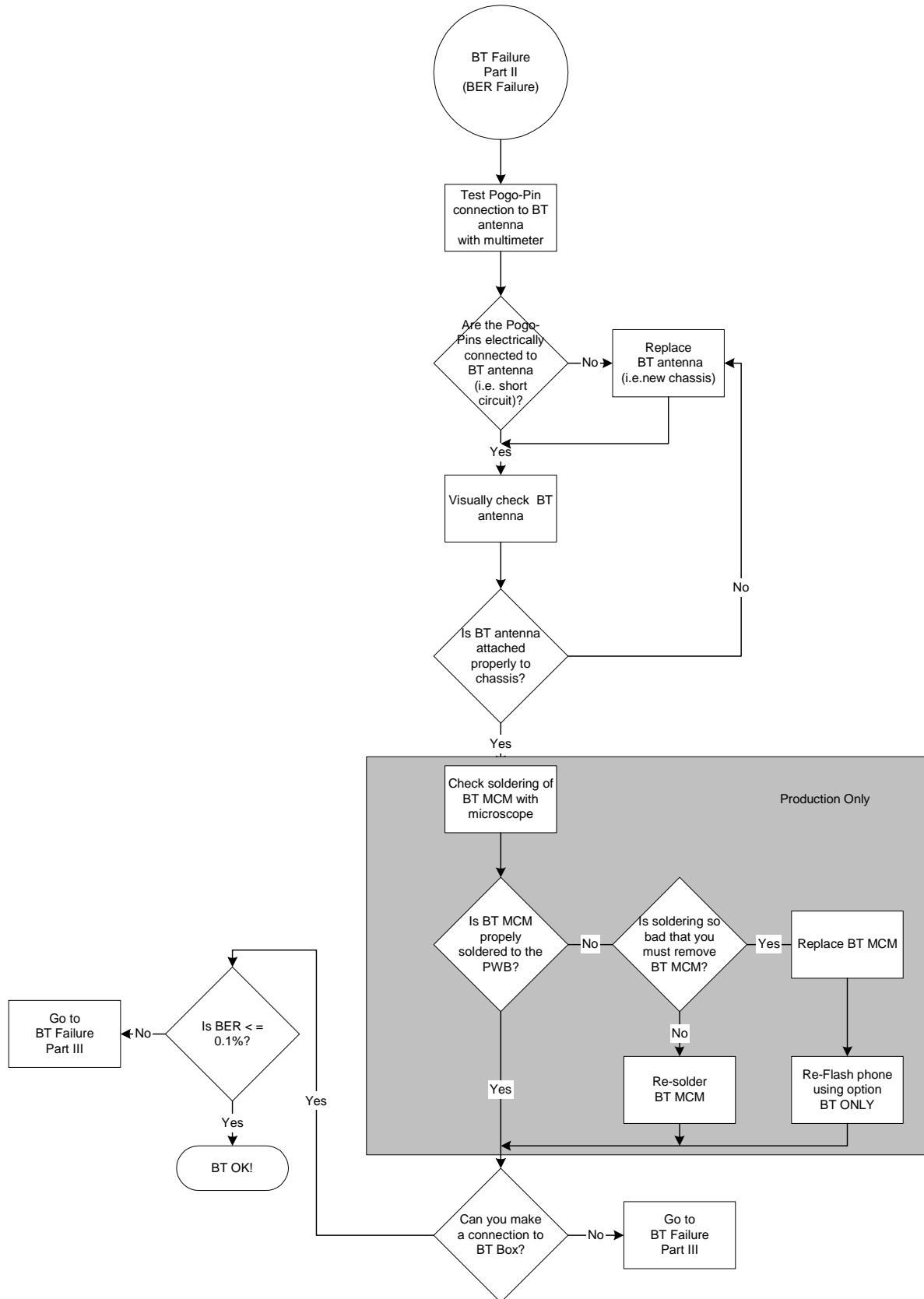

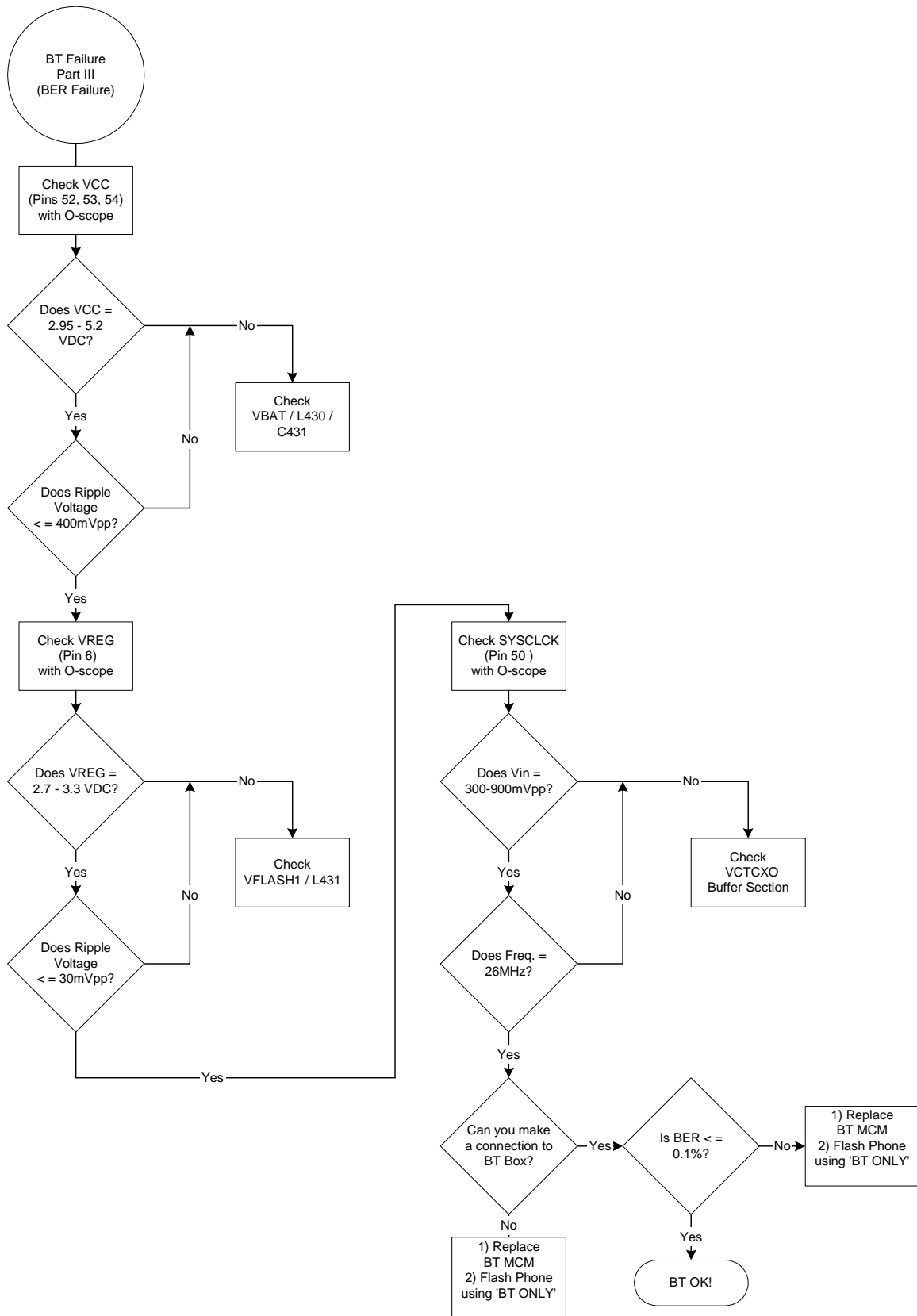

Needed actions if ASIC is changed

UEM changed

If UEM is changed baseband calibrations should be made. IMEI has to be rebuilt to the phone.

AEM changed

If AEM is changed proximity and ambient light sensor calibrations should be achieved.

UPP_WD2 changed

Device has to be reflashed.

Flash0 changed

IMEI has to be reprogrammed. Has to be flashed (naturally). IMEI has to be rebuilt to the phone.

RF component changed

If any RF component changed, RF calibration(tuning) has to be done.

Test points and pin orders

Test points in BaseBand area (LG4_06_02)

J100	RFclk
J101	Sleepclk
J102	SleepX
J103	PURX
J116	Txid
J117	Txqd
J118	Auxda
J119	Rxid
J120	Rxqd
J104	UEMint
J105	AEMSleep
J110	DSPVcc
J106	SDRda0
J107	SDRad0
J108	SDRclk
J109	FLDa0
J111	FLXS1x
J113	FLCS0x
J114	FLOEX
J115	FLClk
J121	I_FBUS_TX
J381	Vbatt
J270	GenVbattIO
J262	Refen

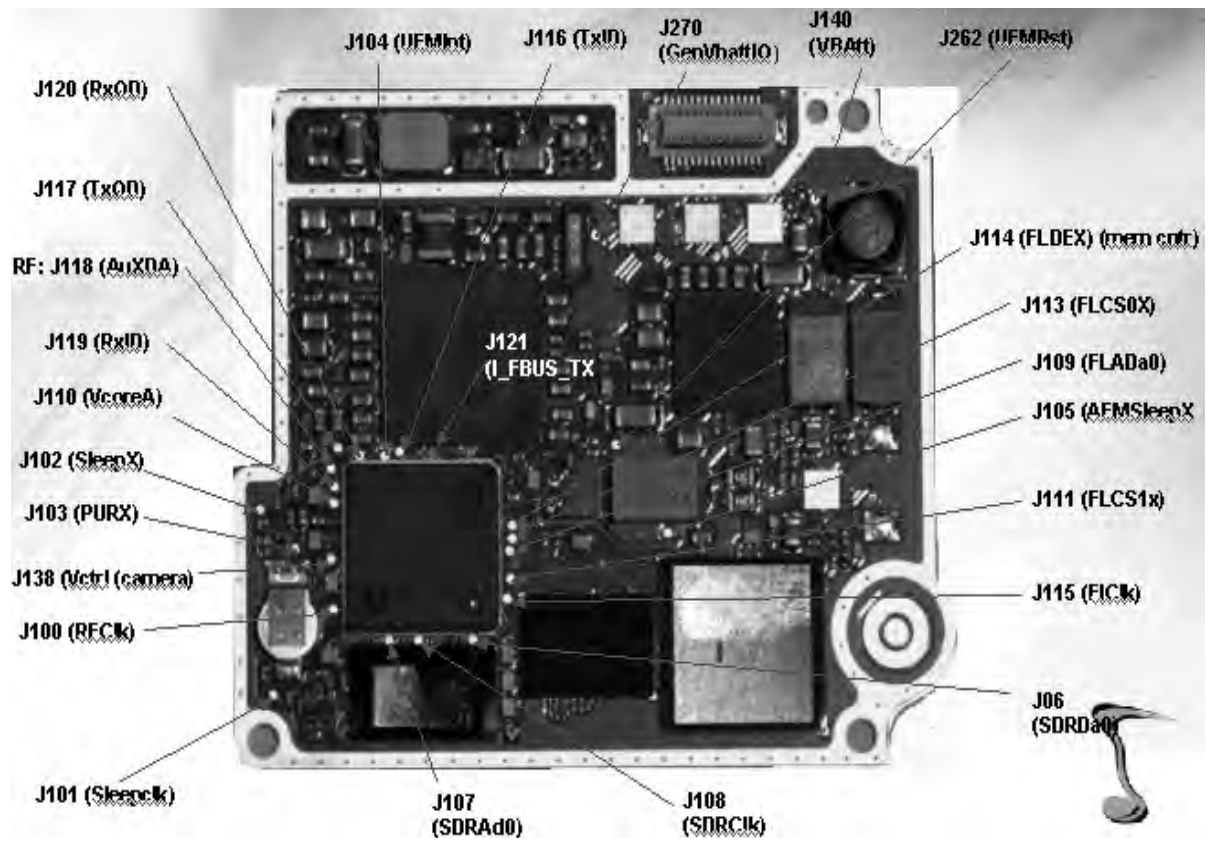

Connectors pin order

UI-connector

Pin no.	Signal name	Type	Typical	Unit	Description
1	VDD	IN	2.78	V	Voltage supply
2	GND		0	V	System ground
3	D4	IN OUT		V	Data to write
				V	Data to read
4	D0	IN OUT		V	Data to write
				V	Data to read
5	A0	IN		V	H: data L: command
6	GND		0	V	System ground
7	VDDI	IN	1.8	V	Logic voltage supply
8	D1	IN OUT		V	Data to write
				V	Data to read
9	D2	IN OUT		V	Data to write
				V	Data to read
10	D3	IN OUT		V	Data to write
				V	Data to read
11	Rocker3		200	mOhm	
12	Rocker2		200	mOhm	
13	GND		0	V	System ground
14	Rocker5		200	mOhm	
15	Rocker4		200	mOhm	
16	Rocker1		200	mOhm	
17	V _{LED+}	IN/ OUT	4.5	V	LED, positive terminal
18	V _{LED-}	IN/ OUT	0	V	LED, negative terminal
19	Row1	IN/ OUT		Ohm	Tracking resistance
				mA	Drive current
20	Row0	IN/ OUT		Ohm	Tracking resistance
				mA	Drive current
				mA	Drive current

21	Col1	IN/ OUT		Ohm	Tracking resistance
				mA	Drive current
22	Col0	IN/ OUT		Ohm	Tracking resistance
				mA	Drive current
23	GND		0	V	System ground
24	RESX	IN		V	Reset (active low)
25	D5	IN OUT		V	Data to write
				V	Data to read
26	D6	IN OUT		V	Data to write
				V	Data to read
27	D7	IN OUT		V	Data to write
				V	Data to read
28	GND		0		System ground
29	RDX	IN			L: read (active low)
30	WRX	IN			L: Write (active low)

Board to board connector

See System Module LG4 and Grip Module LS4”.

Pin order of spring connectors

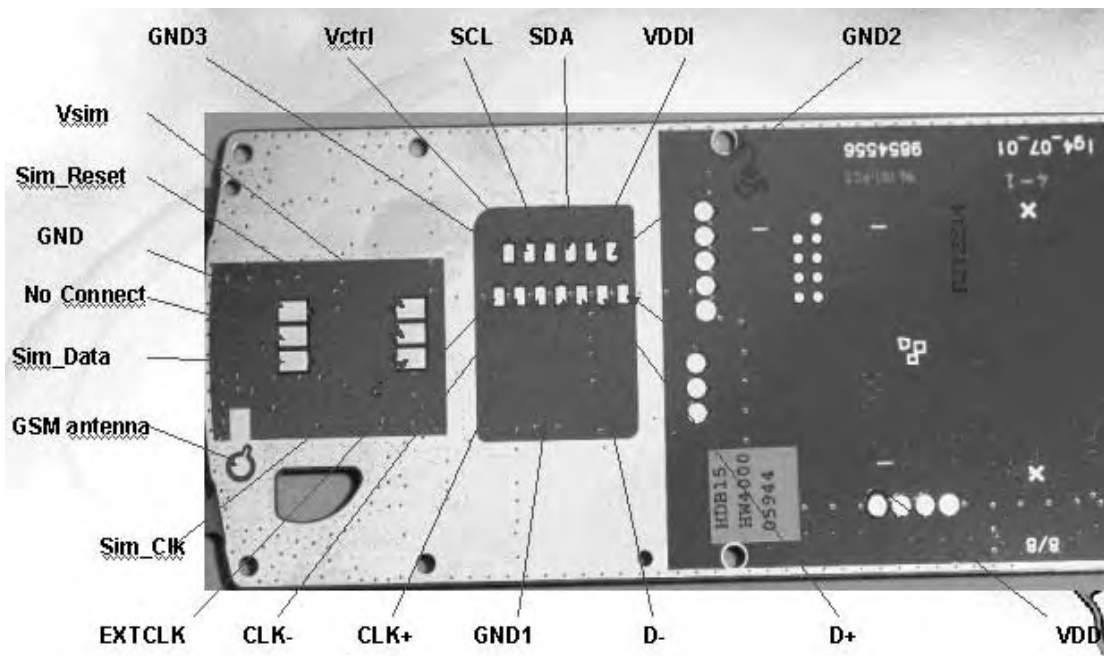
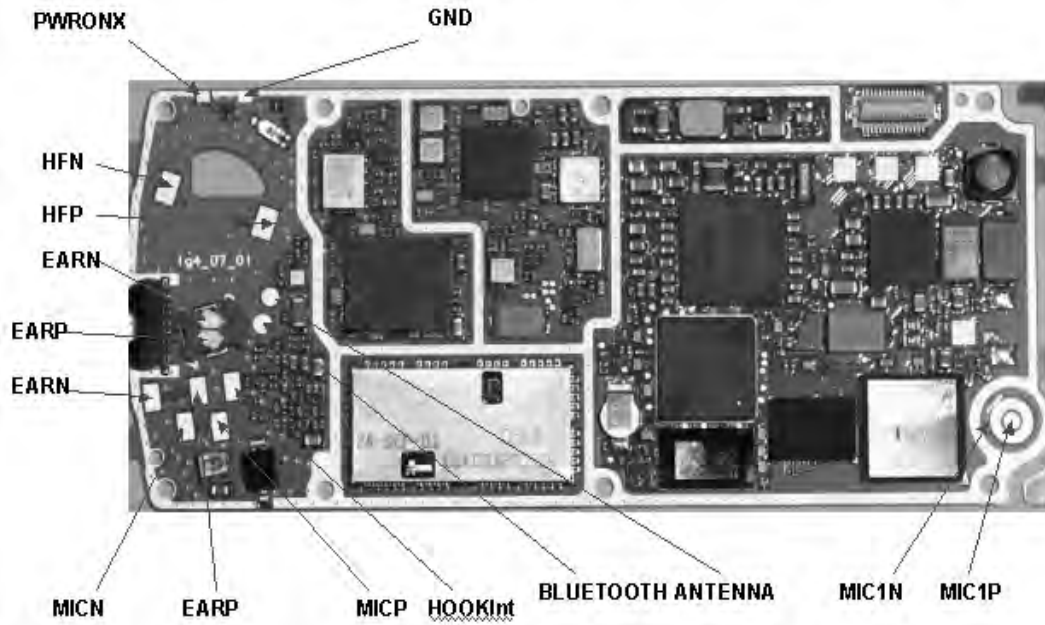

RF Troubleshooting

Introduction

Measurements should be done using Spectrum Analyzer with high-frequency 1kW (20:1) passive probe (LO-/reference frequencies and RF-power levels) and Oscilloscope with a 10:1 probe (DC-voltages and low frequency signals).

Please note that the grounding of the PA-module is directly below PA-module so it is difficult to check or change. **Most RF semiconductors are static discharge sensitive!** So ESD protection must be taken during repair (ground straps and ESD soldering irons). The Hagar IC is moisture sensitive so parts must be pre-baked prior to soldering.

Apart from key-components described in this document here are a lot of discrete components (resistors, inductors and capacitors) which troubleshooting is done by checking if soldering of the component is done properly, for factory repairs (checking if it is missing from PCB). Capacitors can be checked for shortening and resistors for value by means of an ohmmeter, but be aware in-circuit measurements should be evaluated carefully.

Please be aware that all measured voltages or **RF levels in this document are rough figures**. Especially RF levels varies due to different measuring equipment or different grounding of the used probe.

All tuning must be done with Phoenix Service Software, version **02.90.001**, or later.

RF Key component placement

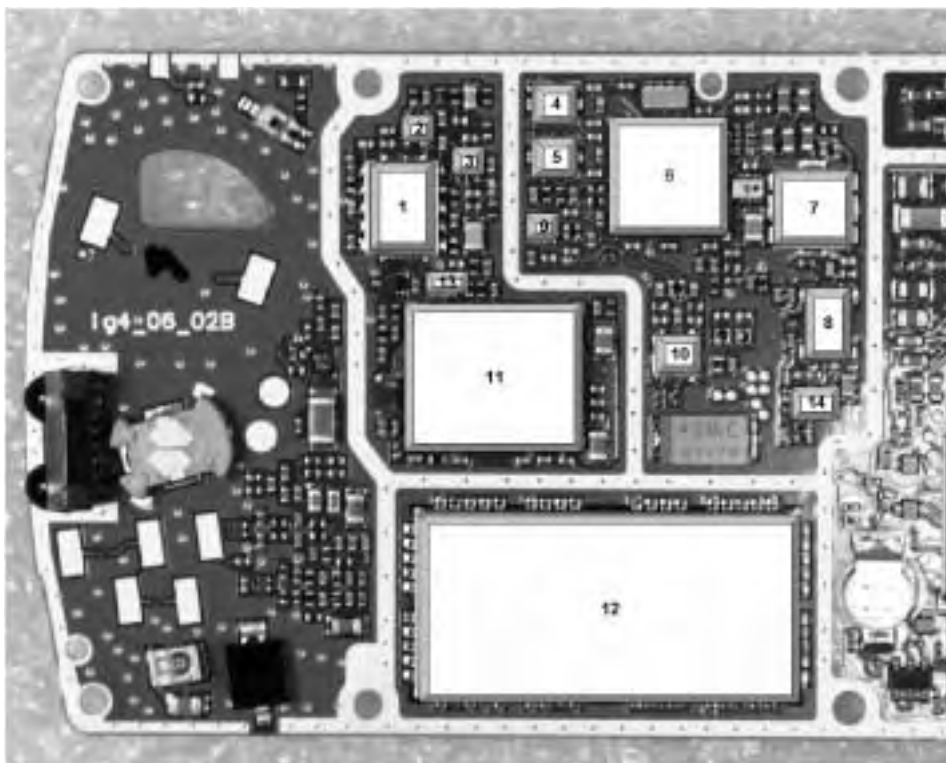
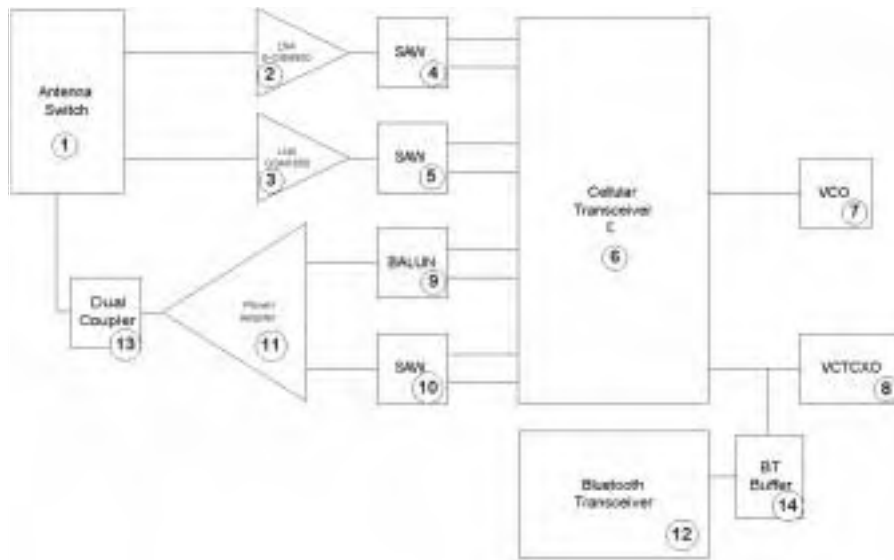

Fault finding test point locations

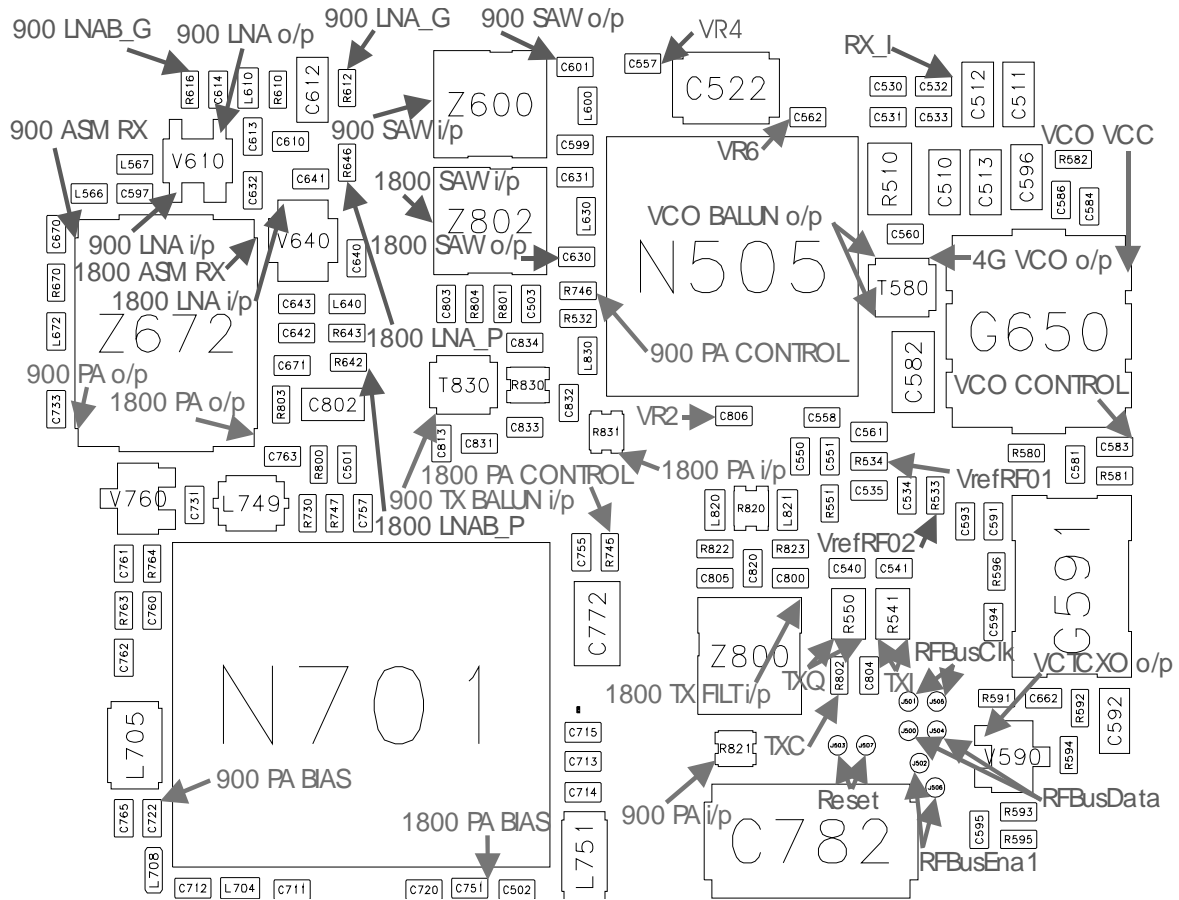

Receiver

General description

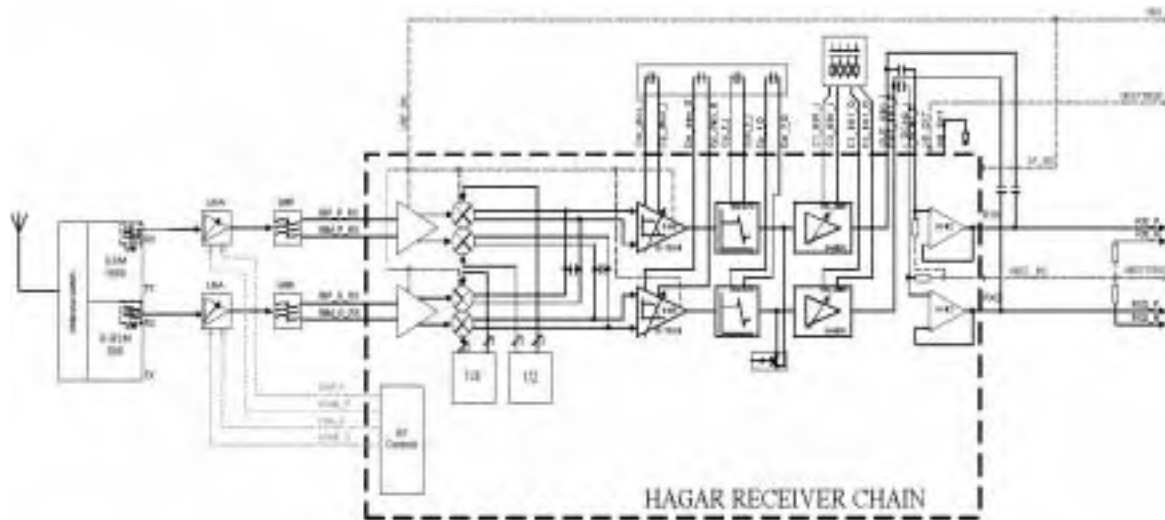

The receiver is a direct-conversion, dual-band linear receiver. RF signal energy gathered by the antenna is fed via the antenna switch module to the 1st RX bandpass SAW filters and MMIC LNAs. The RF antenna switch module provides for upper- and lower-band operation. The signal having been amplified by the LNA is then fed to 2nd RX bandpass SAW filters. Both of these 2nd RX bandpass SAW filters have UNBAL/BAL configuration to achieve the balanced feed for HAGAR. The discrete LNAs have three gain levels. The first one is maximum gain, the second one is about -30dB (GSM1800) and -25dB (E-GSM900) below maximum gain and the last one is off state. The LNA gain selection is controlled directly by HAGAR.

The performance of the RX bandpass SAW filters are mainly responsible for defining the receiver's blocking characteristics against spurious signals outside passband and the protection against spurious responses.

The differential RX signal is amplified and mixed directly down to BB frequency in HAGAR. The LO signal is generated with external VCO. This VCO signal is divided by 2 (GSM1800) or by 4 (E-GSM900). The PLL and dividers are internal to the HAGAR IC. From the mixer output to ADC input RX signal is divided into I- and Q-signals. Accurate phasing is generated in LO dividers. After the mixer DTOS amplifiers convert the differential signals to single ended.

The DTOS has two gain stages. The first one has constant gain of 12dB and 85kHz cut off frequency. The gain of second stage is controlled with control signal g10. If g10 is high (1) the gain is 6dB and if g10 is low (0) the gain of the stage is -4dB. The active channel filters in HAGAR provide selectivity for channels (-3dB @ ± 91 kHz typ.). The integrated

baseband filter inside HAGAR is an active-RC-filter with two off-chip capacitors. Large RC-time constants are needed in the channel select filter of the direct-conversion receiver and are achieved with large off-chip capacitors because the impedance levels could not be increased due to the noise specifications.

The baseband filter consists of two stages, DTOS and BIQUAD. DTOS is differential to single-ended converter having 8dB or 18dB gain. BIQUAD is modified Sallen-Key Biquad. Integrated resistors and capacitors are tunable. These are controlled with a digital control word. The correct control words that compensate for the process variations of integrated resistors and capacitors and of tolerance of off chip capacitors are found with the calibration circuit.

The next stage in the receiver chain is AGC-amplifier, also integrated into HAGAR. AGC has digital gain control via serial mode bms. AGC-stage provides gain control range (40 dB, 10 dB steps) for the receiver and also the necessary DC compensation. Additional 10 dB AGC step is implemented in DTOS stages.

DC compensation is made during DCN1 and DCN2 operations (controlled via serial bus). DCN1 is carried out by charging the large external capacitors in AGC stages to a voltage which effect a zero dc-offset. DCN2 set the signal offset to constant value (V_{refRF_02} 1.35 V). The V_{refRF_02} signal is used as a zero level to RX ADCs.

Single ended filtered I/Q-signal is then fed to ADCs in BB. Input level for ADC is $1.45 V_{pp}$ max.

Rf-temp port is intended to be used for compensation of RX SAW filters thermal behavior. This phenomena will have impact to RSSI reporting accuracy. The current information is -35ppm/C for center frequency drift for all bands. This temperature information is a voltage over two diodes and diodes are fed with constant current.

E-GSM900

E-GSM900 RX Troubleshooting Setup steps

1	Place the phone in the test jig
2	File → Choose Product → Calypso
3	From 'Toolbar' set operating mode to Local
4	Maintenance → Testing → RF Controls
5	Select band 'GSM900'
6	Set Active unit to 'Rx'
7	Set Operation mode to 'Continuous'
8	Set AGC to '8:FEG ON +46 dB'
9	Set Rx/Tx channel to 37



Troubleshooting diagram for GSM900 receiver:

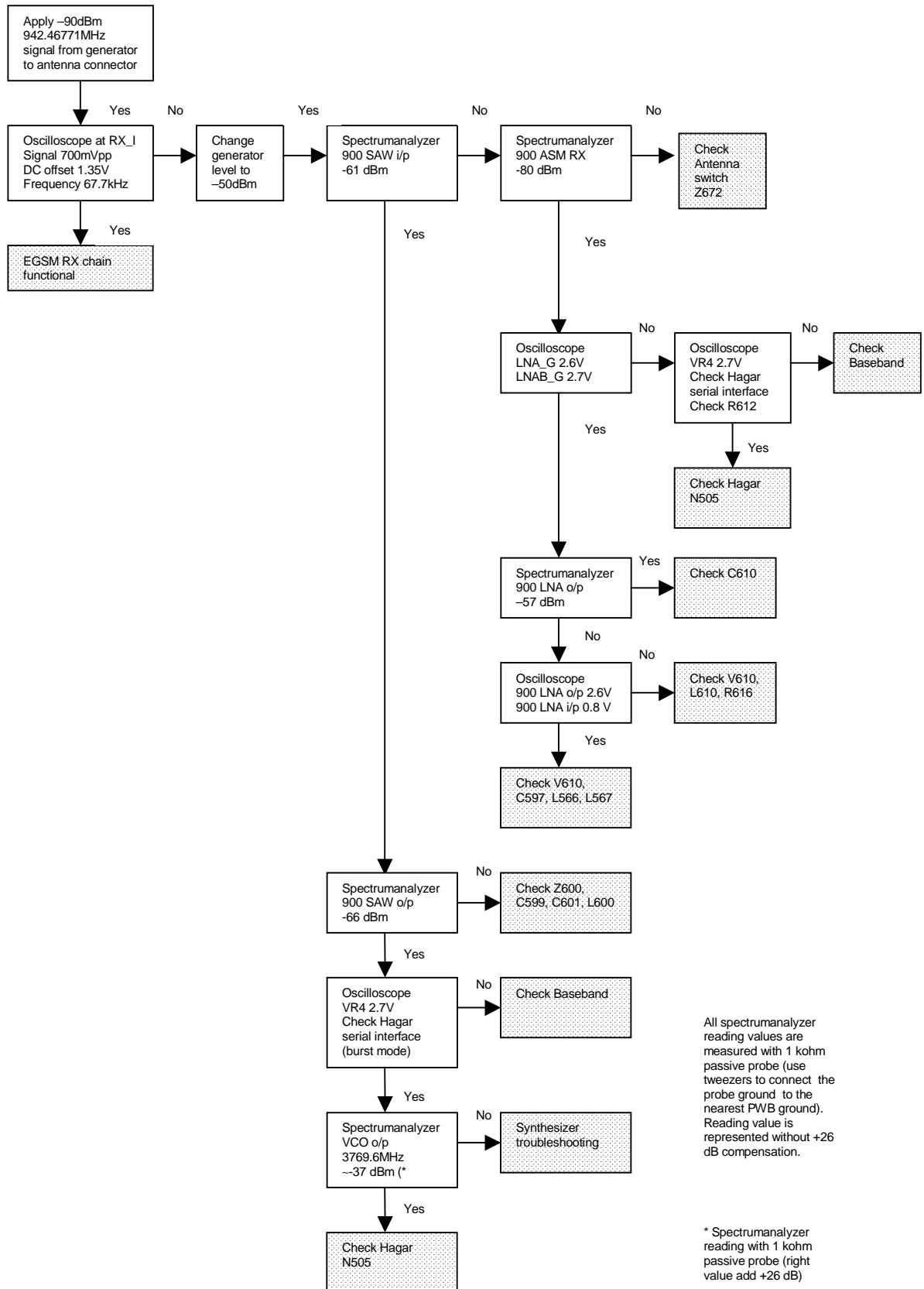

All spectrum analyzer reading values are measured with 1 kohm passive probe (use tweezers to connect the probe ground to the nearest PWB ground). Reading value is represented without +26 dB compensation.

* Spectrum analyzer reading with 1 kohm passive probe (right value add +26 dB)

GSM1800

GSM1800 RX Troubleshooting Setup steps:

1	Place the phone in the test jig
2	File → Choose Product → Calypso
3	From 'Toolbar' set operating mode to Local
4	Maintenance → Testing → RF Controls
5	Select band 'PCN'
6	Set Active unit to 'Rx'
7	Set Operation mode to 'Continuous'
8	Set AGC to '8:FEG ON +46 dB'
9	Set Rx/Tx channel to 700

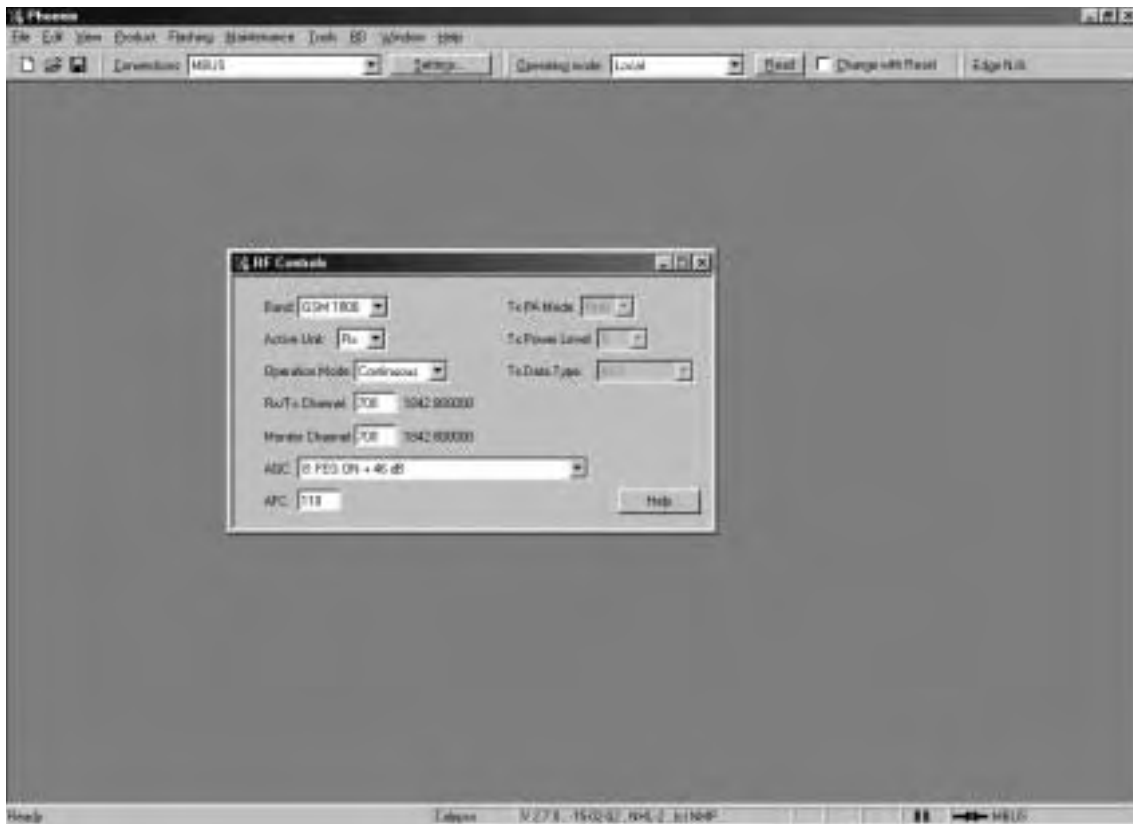

Troubleshooting diagram for GSM1800 receiver

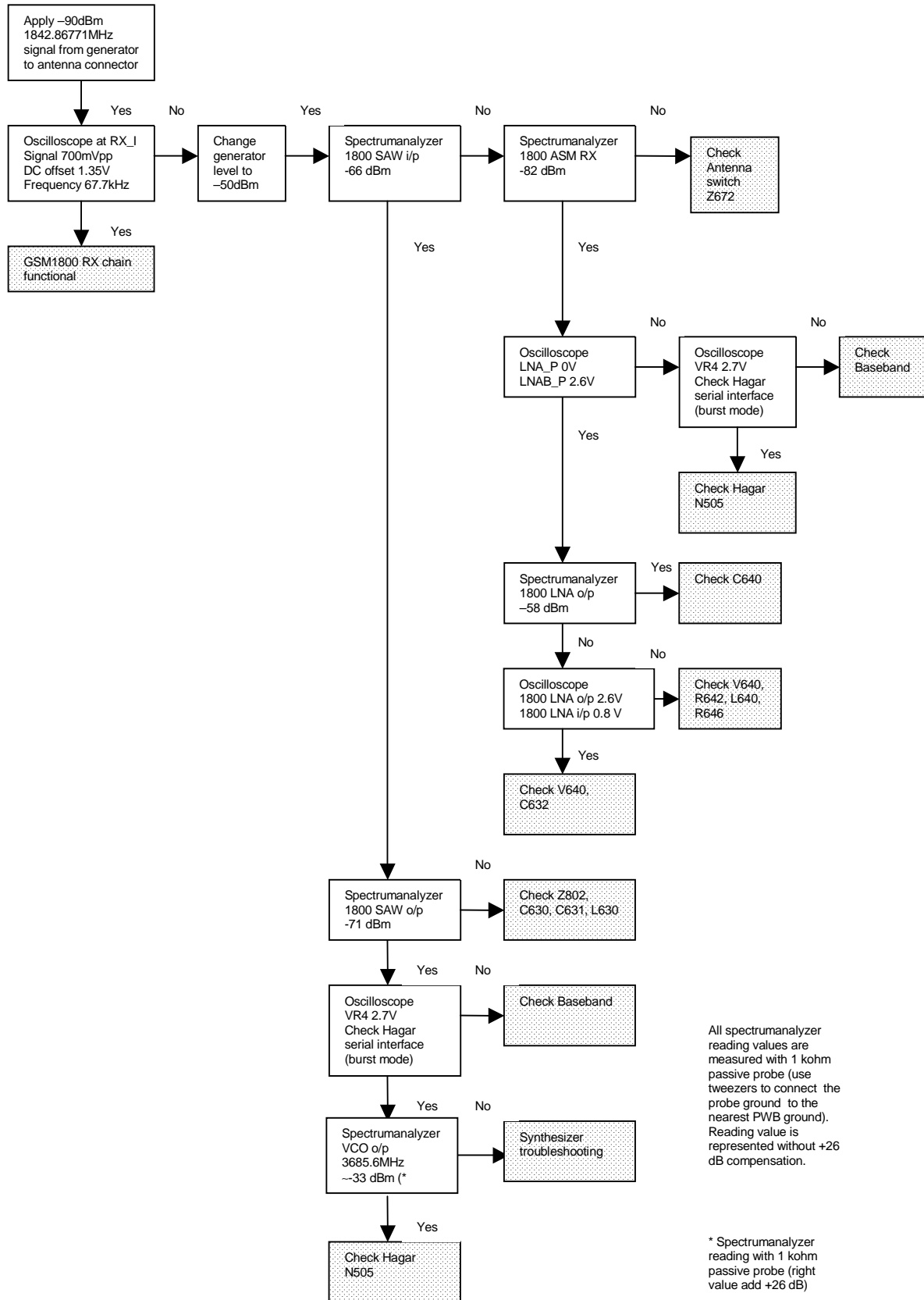

Picture of RX signal

Figure 1: Example of RX_I (or RX_Q) signal at -90dBm signal level

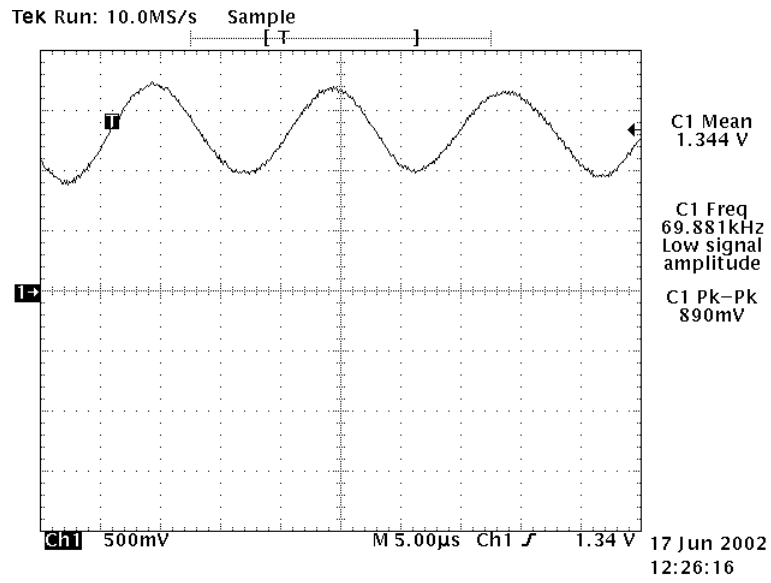

Transmitter

General description

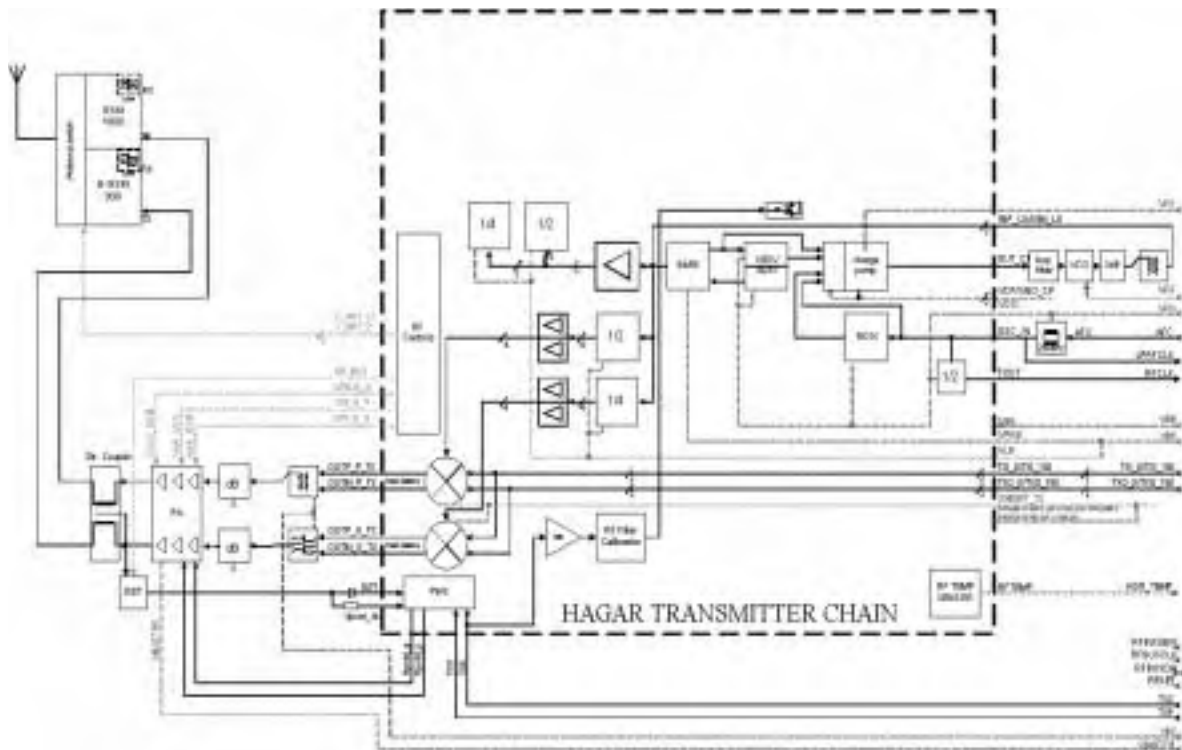

The transmitter chain consists of two final frequency I/Q-modulators, one for E-GSM900 and the other for the GSM1800 band, a dual power amplifier and a power control loop. The I- and Q-signals are generated by baseband. After post filtering (RC network) they go into IQ-modulator in HAGAR. The LO signal for the modulator is generated by the external VCO and is divided by 2 or by 4 depending on the system mode. There are separate outputs one for E-GSM900 and one for GSM1800.

In the E-GSM900 branch, a SAW filter is placed before PA to attenuate unwanted signals and wide-band noise from the HAGAR IC.

The final amplification is realized with dual band power amplifier. It has two separate power chains one for E-GSM900 and one for GSM1800. The PA is capable of producing in excess of 2 W (0 dBm input level) in the E-GSM900 band and over 1 W (0 dBm input level) in the GSM1800 band assuming a 50 W output. The gain control range is over 45 dB to achieve the desired power levels and power ramp/decay performance.

Harmonics generated by the nonlinear PA are filtered out with filtering inside the antenna switch -module.

Power control circuitry consists of discrete power detector (common to E-GSM900 and GSM1800 bands) and error amplifier internal to HAGAR. There is a directional coupler connected between PA output and antenna switch. It is a dual-band type and has input and outputs for both systems. Dir. coupler takes a sample from the forward going power with certain ratio. This signal is rectified using a Schottky-diode and produces a DC-signal after filtering.

E-GSM900

Figure 2: E-GSM900 TX Troubleshooting Setup steps

1	Place the phone in the test jig
2	File → Choose Product → Calypso
3	From 'Toolbar' set operating mode to Local
4	Maintenance → Testing → RF Controls
5	Select band 'GSM900'
6	Set Active unit to 'Tx'
7	Set Operation mode to 'Burst'
8	Set TX data type to 'Random'
9	Set Rx/Tx channel to 37
10	Set Tx PA mode to 'Free'
11	Set power level to 5

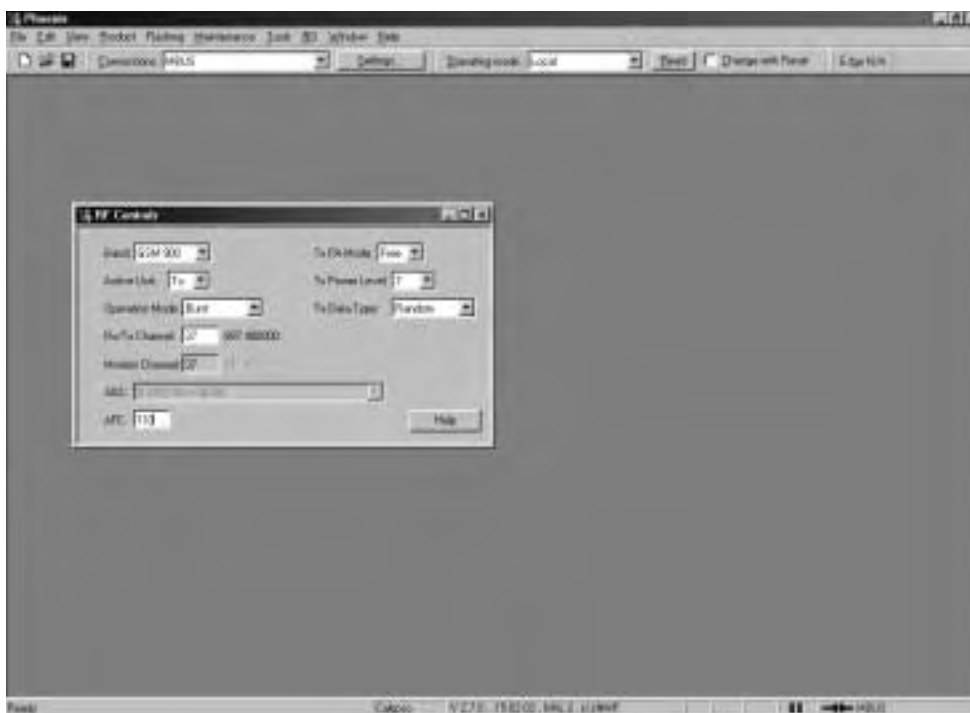

GSM1800

Figure 3: GSM 1800 TX Troubleshooting Setup steps

1	Place the phone in the test jig
2	File → Choose Product → Calypso
3	From 'Toolbar' set operating mode to Local
4	Maintenance → Testing → RF Controls
5	Select band 'PCN'
6	Set Active unit to 'Tx'
7	Set Operation mode to 'Burst'
8	Set TX data type to 'Random'
9	Set Rx/Tx channel to 700
10	Set Tx PA mode to 'Free'
11	Set power level to 0

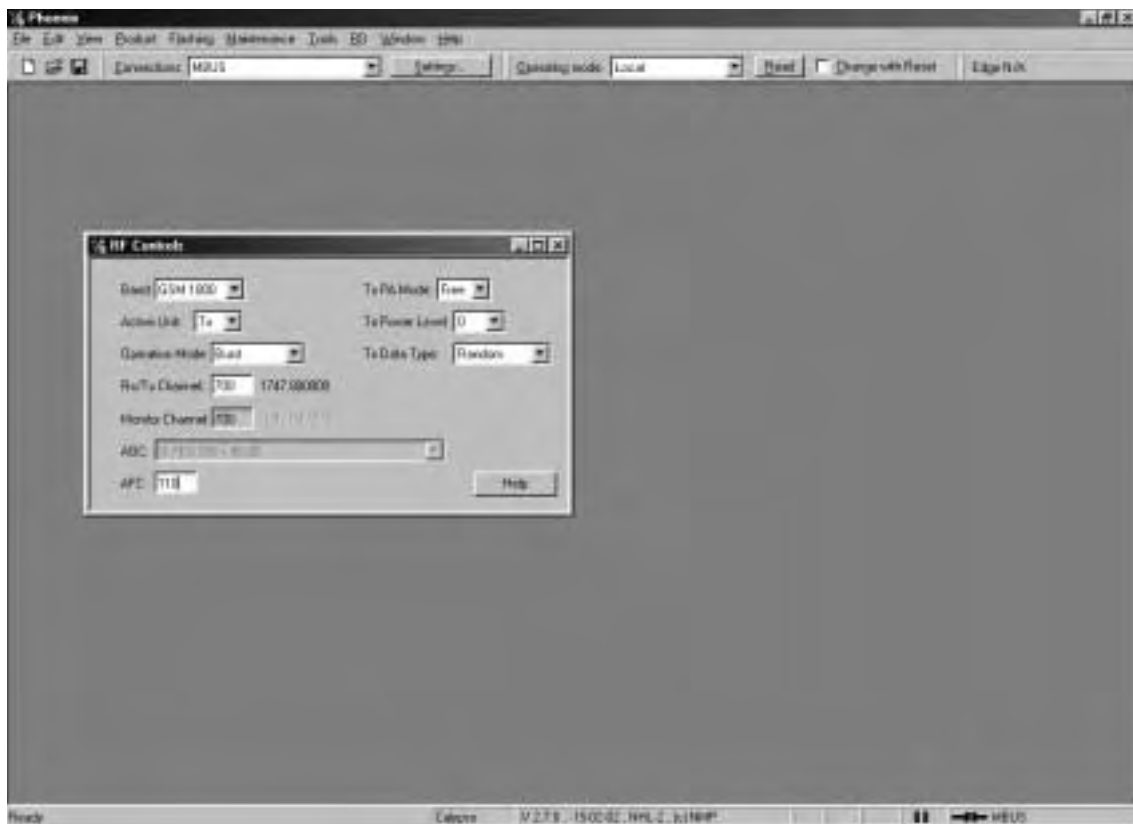

Fault finding tree

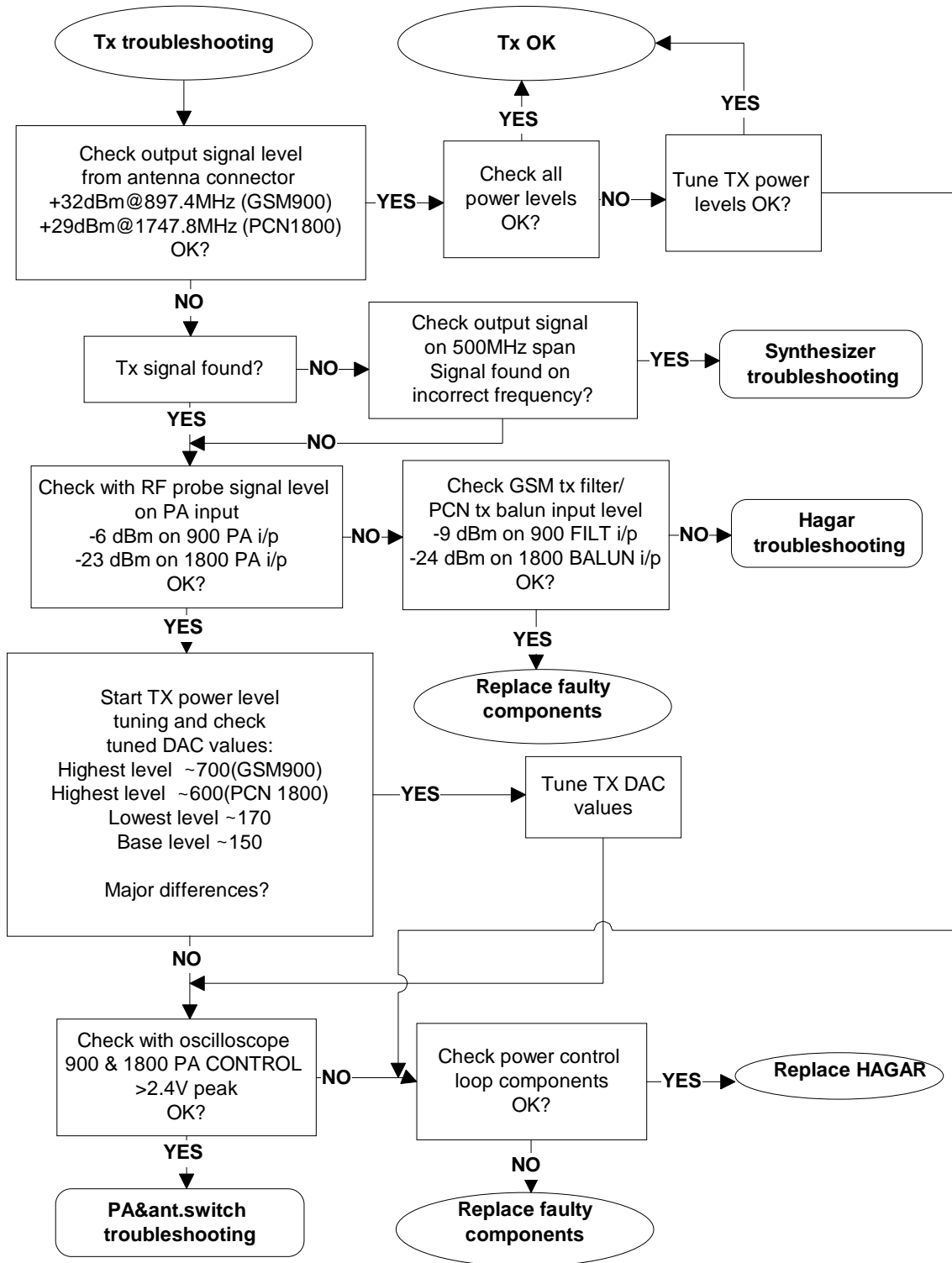

Example of TX signals

Figure 4: Example of TXI signal

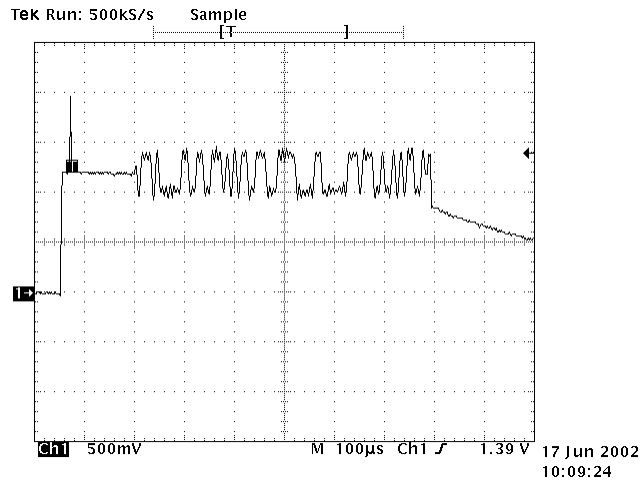

Figure 5: Example of TXQ signal

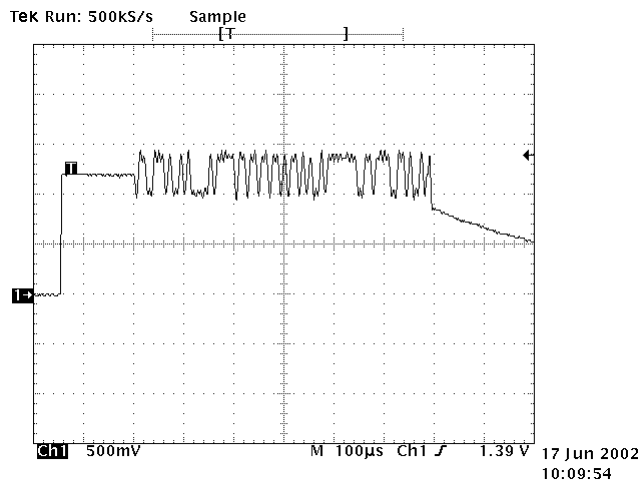

Figure 6: Example of VC2 signal

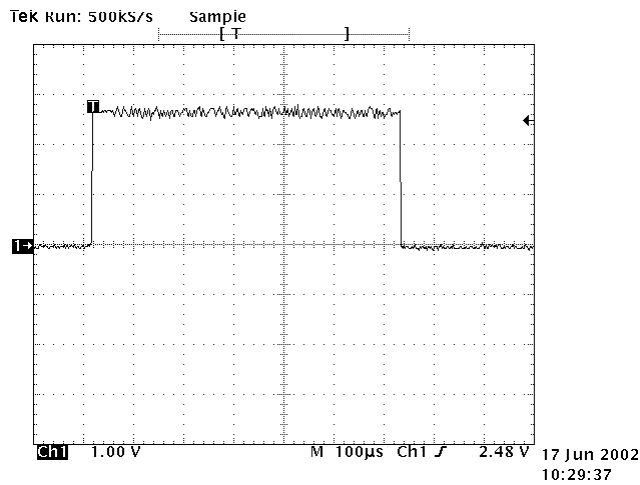

Figure 7: Example of 900/1800 PA BIAS signal

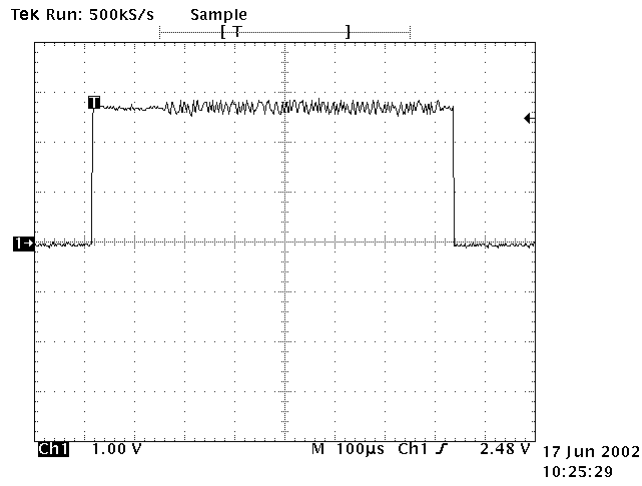

Figure 8: Example of 900/1800 PA CONTROL signal

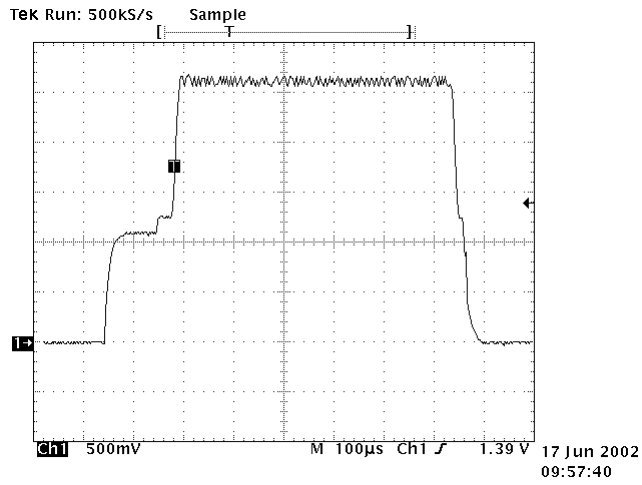
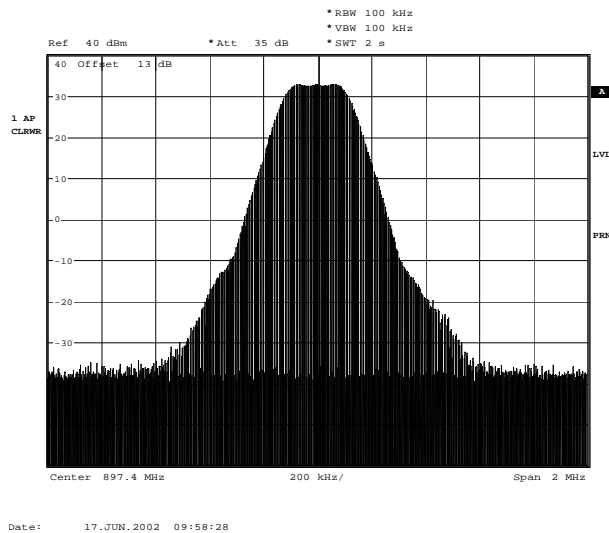

Figure 9: Example of 900 TX burst from antenna connector



Common

Antenna switch control logic (reference Z672)

	VC1	VC2
900 TX	LOW	HIGH
1800 TX	HIGH	LOW
RX	LOW	LOW

VCTCXO (reference G591)

Figure 10: Example of VCTCXO o/p signal

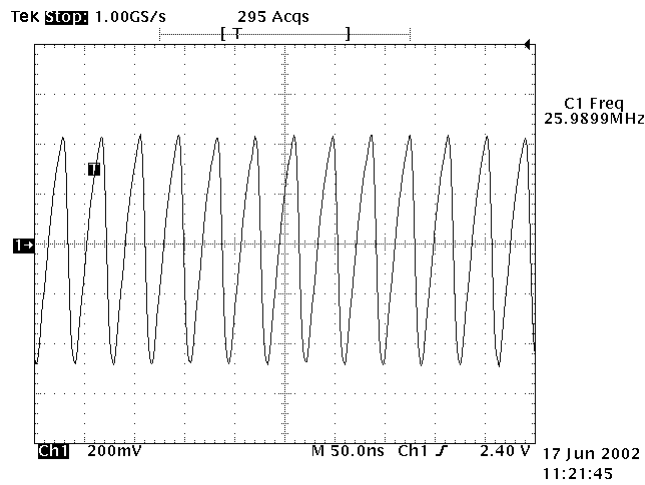

Frequency synthesizer

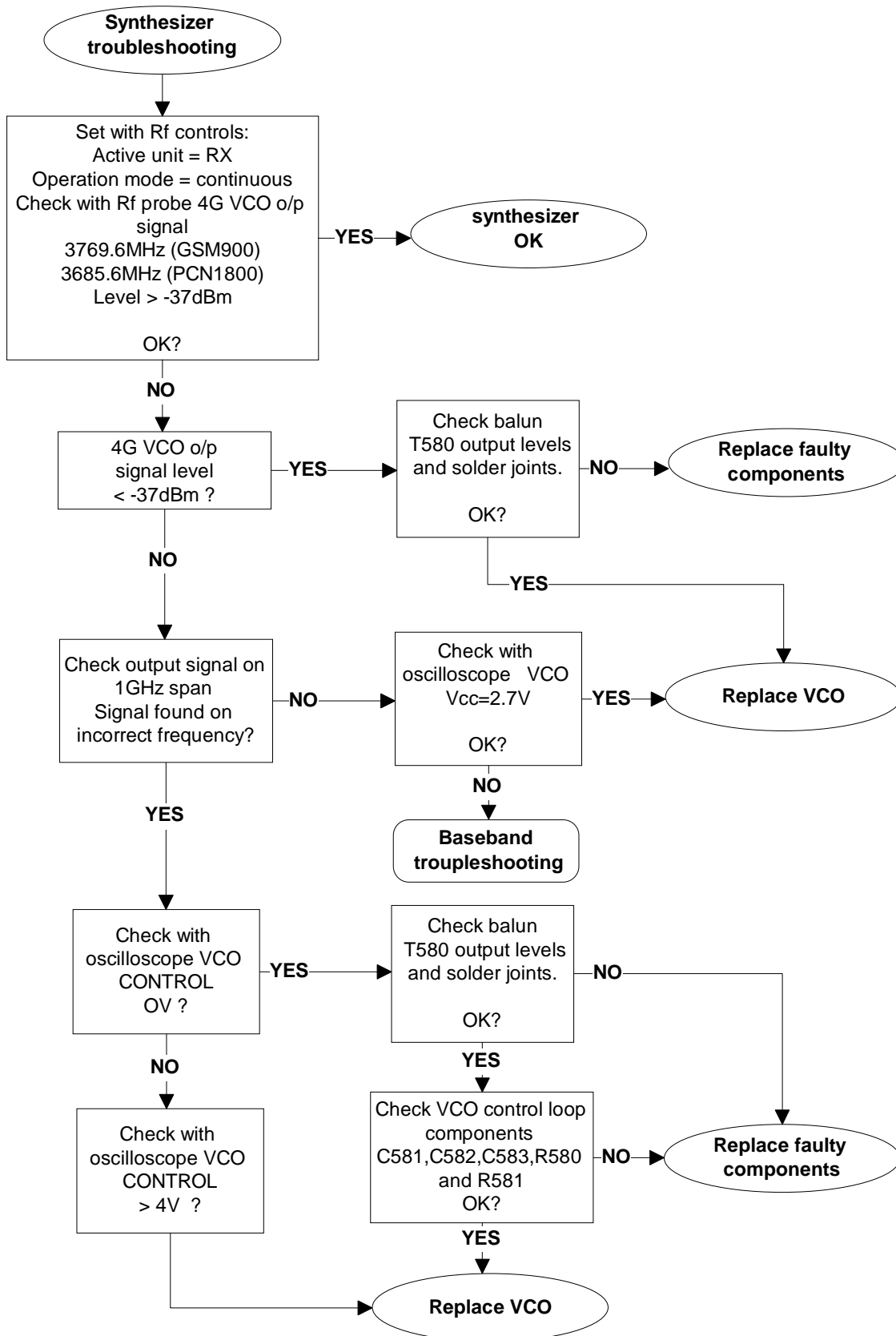

Example of synthesizer signal

Figure 11: Example of 4G VCO o/p signal

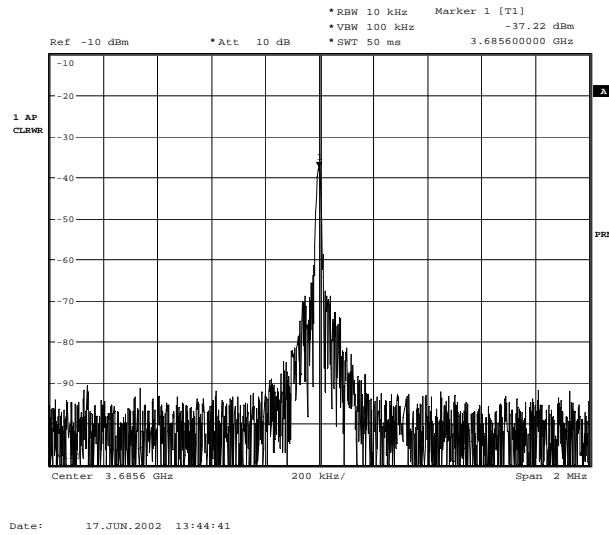

Figure 12: Example of 4G VCO CONTROL signal, 900 RX, channel 124, continuous mode

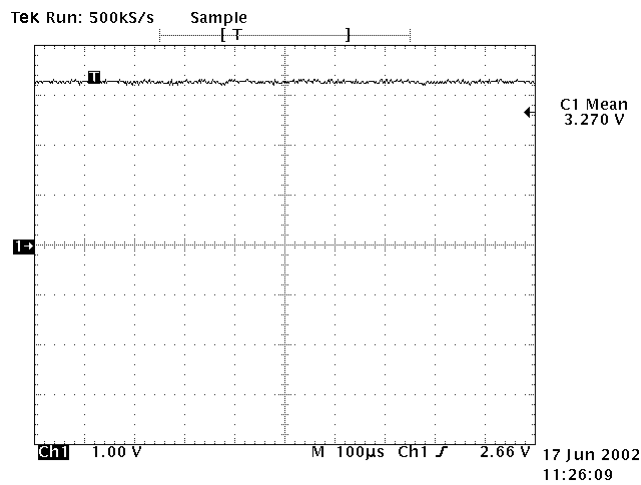
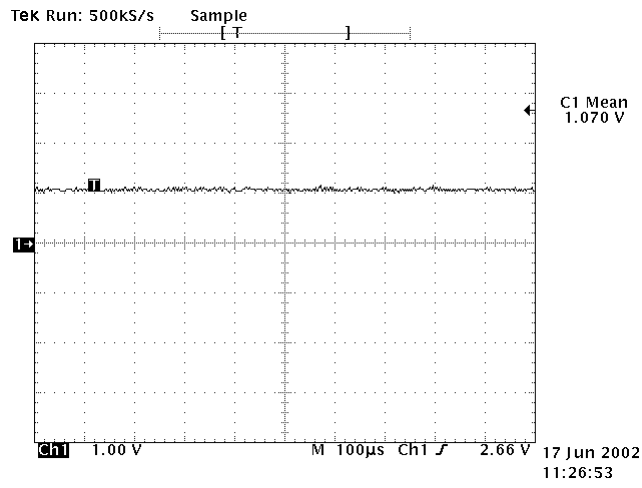
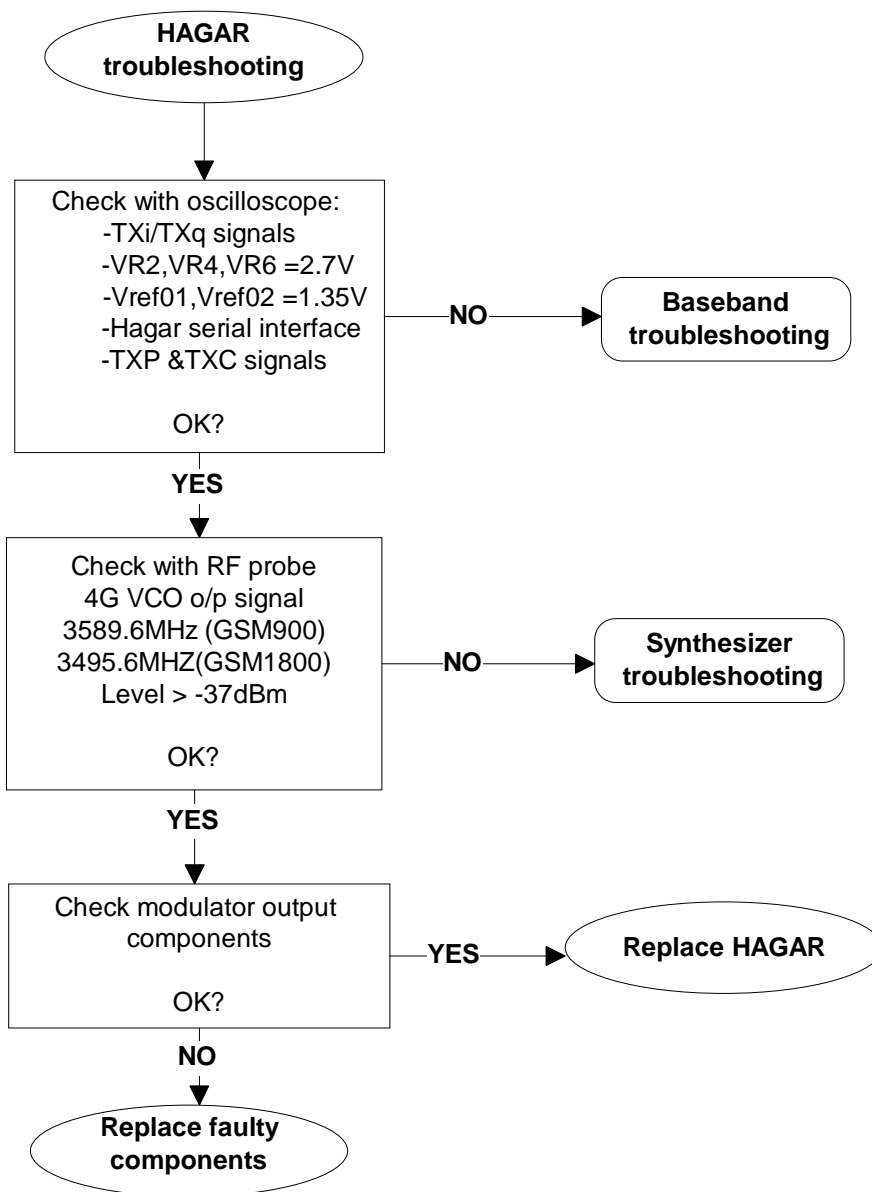

Figure 13: Example of 4G VCO CONTROL signal, 1800 TX, channel 512, continuous mode



HAGAR



PA and Antenna switch

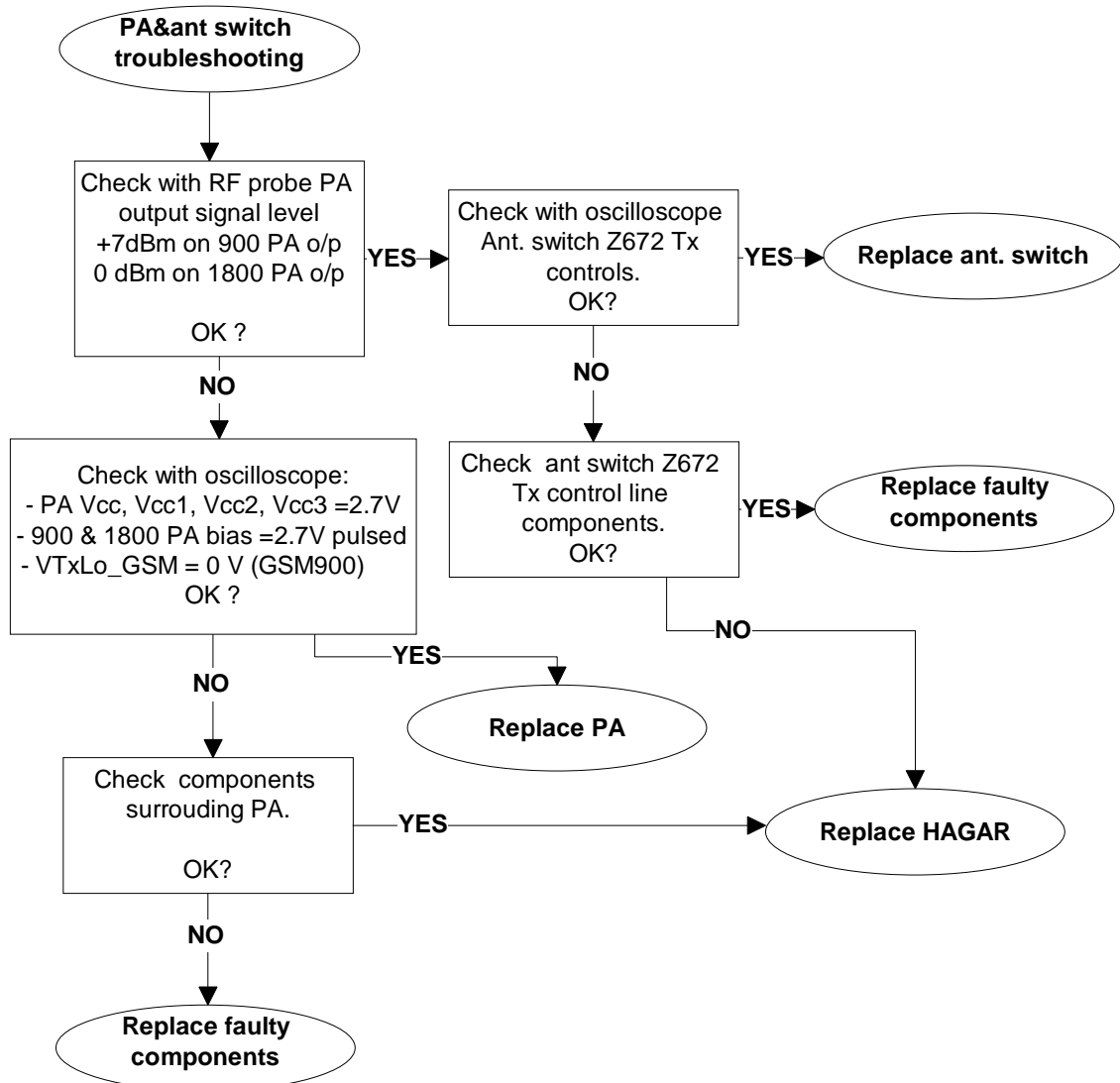

Receiver tunings

RX Channel Select Filter Calibration

- Extra equipment / external RF signal not needed
- Must be done before other RX calibrations
- This function is used to calibrate RX channel select filter in GSM Phones.
- Rx Channel select filter is tuned only in one band = Single calibration for both bands
- Select Maintenance => Tuning => Rx Channel select filter calibration

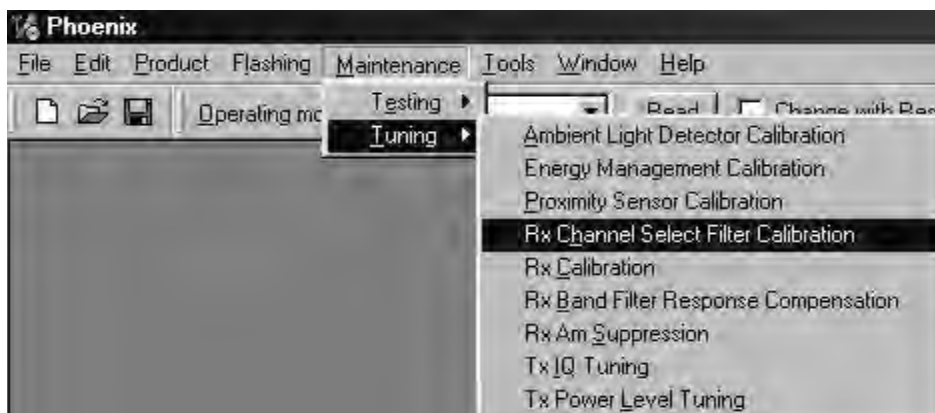

- Select "Yes" to start tuning with values already saved to the phone

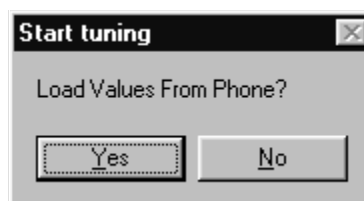

- Press "AutoTune" to start the tuning



- Tuning values should be 0...31
- Select "Stop"
- If values shown are within limits, choose "Yes" to save values to the phone save them to phone.

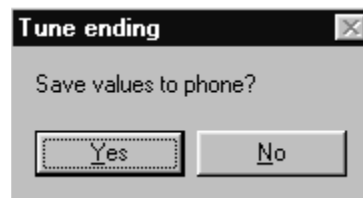

- Close the "RX Channel Select Filter Calibration" dialog to end tuning

RX Calibration

- RF generator needed
- This tuning performs RX Calibration
- Must be done separately on both bands!
- Start RX Calibration at EGSM (GSM900), then do RX Calibration at GSM1800 band.
- AFC tuning is done while EGSM (GSM900) band RX Calibration is performed.
- *Remember to take jig and cable attenuations into account!*
- Select Maintenance => Tuning => Rx calibration

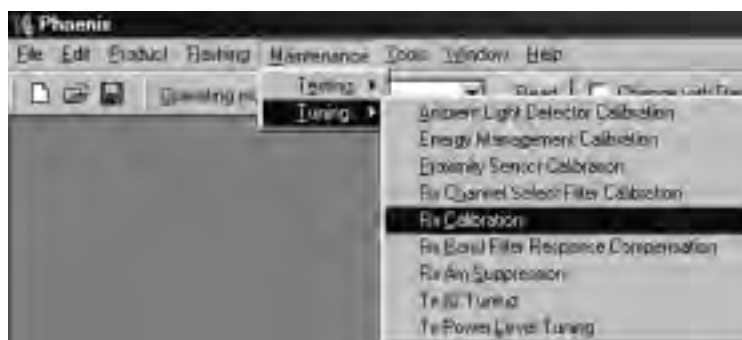

- When RX Calibration has been started, you can choose the correct band from the dropdown menu. Begin tuning from EGSM 900 band.

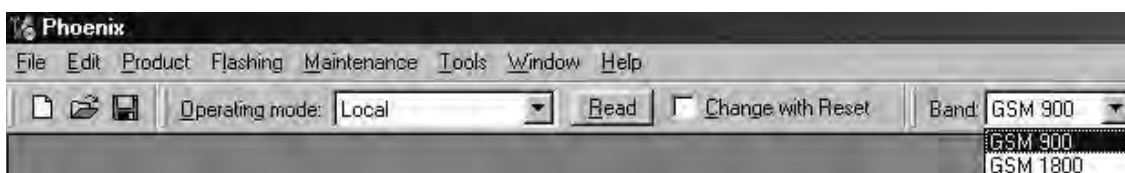

- Press "Start"



- Select "Default" to start tuning from factory default values => OK

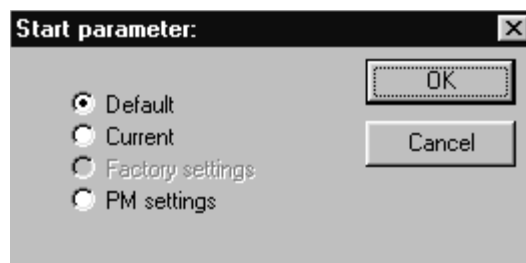

- Set the Calibration mode to "Automatic"
- Press "Calibrate"



- Set RF generator to required frequency => OK

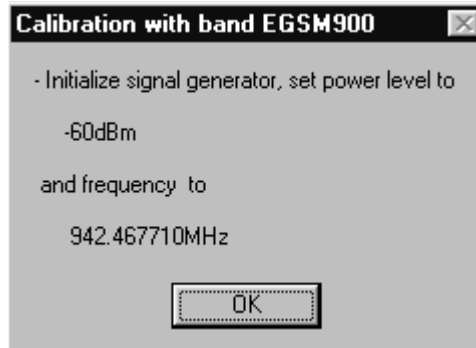

Tuning values and ADC readings will be shown

Typical values and limits in (GSM900) RX Calibration:

EGSM (GSM900)	Typical value	Limits
AFC value	-176	-350...+350
AFC slope	269	150...350
RSSI0	74	67...77
RSSI1	84	77...87
RSSI2	94	87...97
RSSI3	99.5	94...104
RSSI4	109.5	104...114
RSSI5	119.5	114...124
RSSI6	129.5	124...134
RSSI7	139.5	134...144
RSSI8	149.5	144...152

- Choose "Stop" to end tuning
- If values shown are within limits, choose "Yes" to save values to the phone

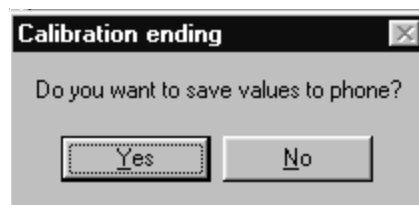

- Continue tuning from GSM1800. Choose the correct band from the dropdown menu.
- Press "Start" to continue just like in the EGSM900 Band above.



When asked, set RF generator to required frequency => OK



Typical values and limits in (GSM1800) RX Calibration:

GSM1800	Typical value	Limits
RSSI0	66.5	63...73
RSSI1	76.5	73...83
RSSI2	86.5	83...93
RSSI3	99.5	94...104
RSSI4	109.5	104...114
RSSI5	119.5	114...124
RSSI6	129.5	124...134
RSSI7	139.5	134...144
RSSI8	149.5	144...152.5

- Choose "Stop" to end tuning
- If values shown are within limits, choose "Yes" to save values to the phone

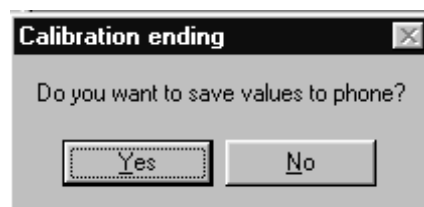

- Close the "RX – Calibration – dialog to end tuning

RX Band Filter Response Compensation

- RF generator needed
- Must be done separately on both bands!
- Start RX Band Filter Response Compensation at EGSM (GSM900), then do RX Band Filter Response Compensation at GSM1800 band.
- *Note: Remember to do RX calibration before doing Rx Band Filter Response Compensation!*
- Remember to take jig and cable attenuations into account!
- Select Maintenance => Tuning => Rx band filter response compensation

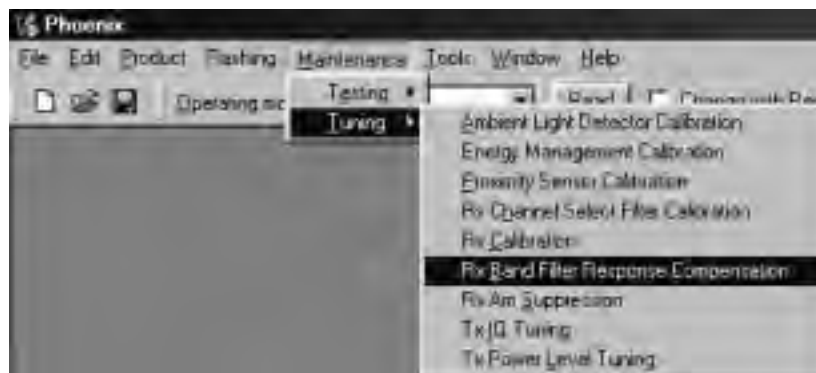

- Select "Yes" to start tuning with values already saved to the phone

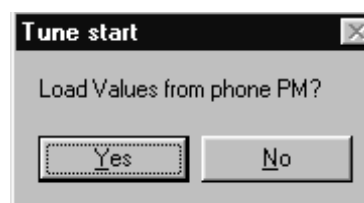

- Select "Manual tuning"



- You will be asked to supply 9 different RF frequencies to the phone
- Set first required frequency and level => OK

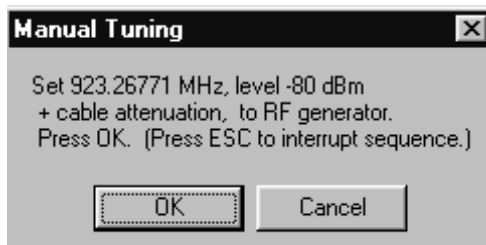

- Set 2nd required frequency and level => OK

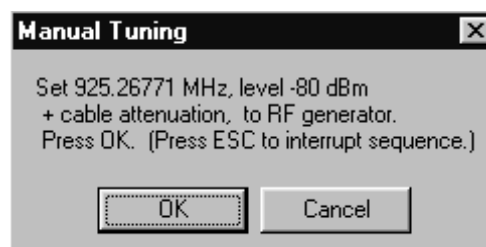

- Set 3rd required frequency and level => OK

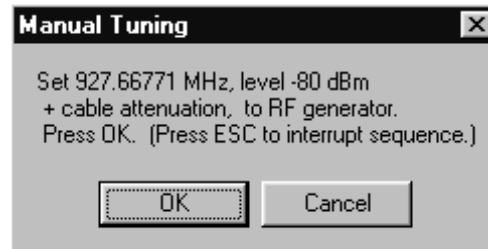

- Set 4th required frequency and level => OK

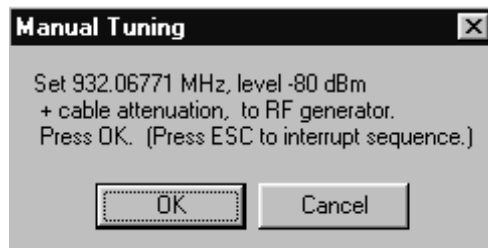

- Set 5th required frequency and level => OK

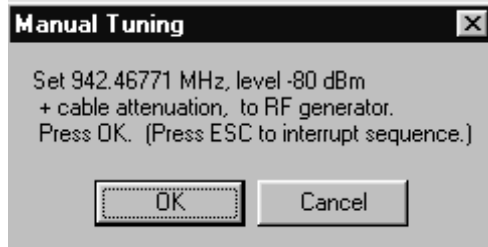

- Set 6th required frequency and level => OK

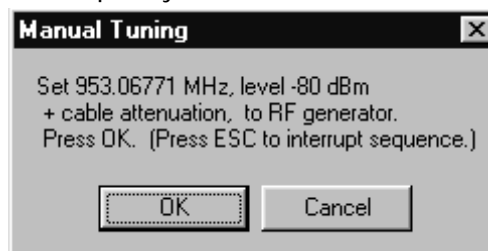

Set 7th required frequency and level => OK

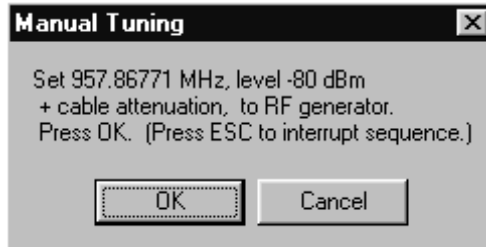

Set 8th required frequency and level => OK

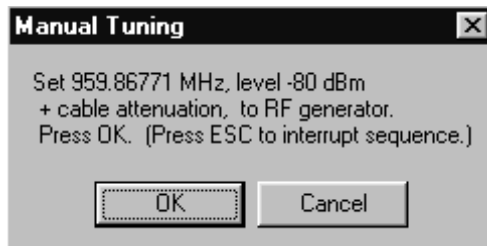

Set 9th required frequency and level => OK

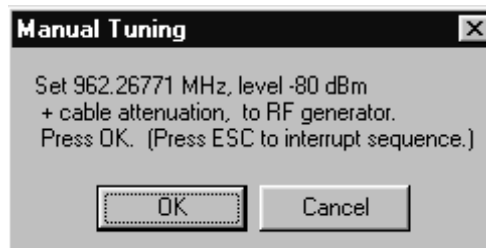

Typical values and limits in Rx Band Filter Response Compensation EGSM900:

Channel Input frequency (MHz) Measured level difference (dB) Limits (dB)

Channel	Input frequency (MHz)	Measured level difference (dB)	Limits (dB)
965	923.26771	-0.118	-10...+5
975	925.26771	0.511	-5...+5
987	927.66771	0.857	-5...+5
1009	932.06771	1.174	-5...+5
37	942.46771	0.569	-5...+5
90	953.06771	1.928	-5...+5
114	957.86771	0.964	5...+5
124	959.86771	0.545	-5...+5
136	962.26771	-0.040	-10...+5

- Choose "Stop, write to PM area"

- If values shown are within limits, choose "Yes" to save values to the phone

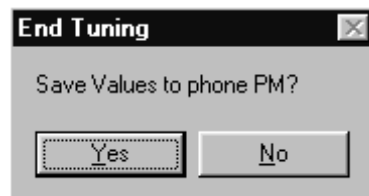

Continue tuning from GSM1800. Choose the correct band from the dropdown menu.

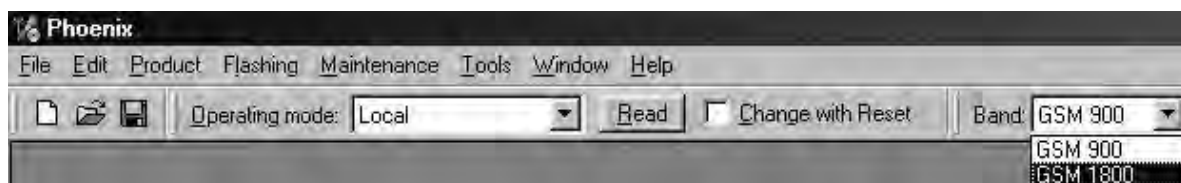

- Repeat the same steps as for the EGSM900 band above

Typical values and limits in Rx Band Filter Response Compensation GSM1800:

Channel Input frequency (MHz) Measured level difference (dB) Limits (dB)

497	1802.26771	0.214	-10...+5
512	1805.26771	1.739	-5...+5
535	1809.86771	2.056	-5...+5
606	1824.06771	1.632	-5...+5
700	1842.86771	0.583	-5...+5
791	1861.06771	0.734	-5...+5
870	1876.86771	0.616	-5...+5
885	1879.86771	0.185	-5...+5
908	1884.46771	-1.132	-10...+5

- If values shown are within limits, save values to the phone
- Close the "RX Band Filter Response Compensation" – dialog to end tuning

RX AM Suppression

- RF generator needed (AM modulation)
- Must be done separately on both bands!
- Start RX AM Suppression at EGSM (GSM900), then do RX AM Suppression at GSM1800 band.
- This dialog performs RX AM Suppression.
- Remember to take jig and cable attenuations into account!
- Select Maintenance => Tuning => Rx Am suppression

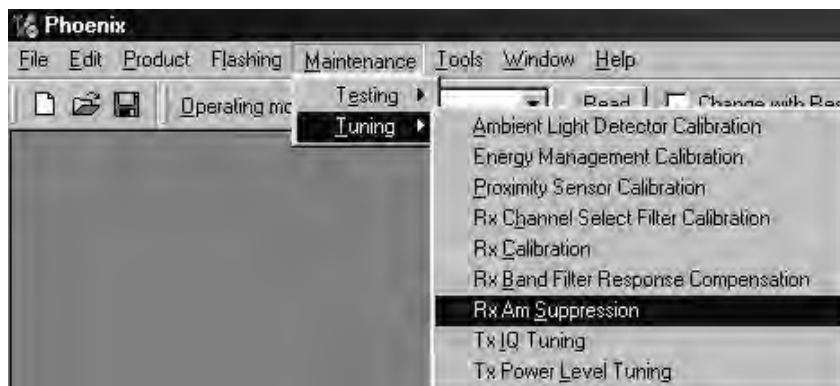

- Start => Default settings => OK,

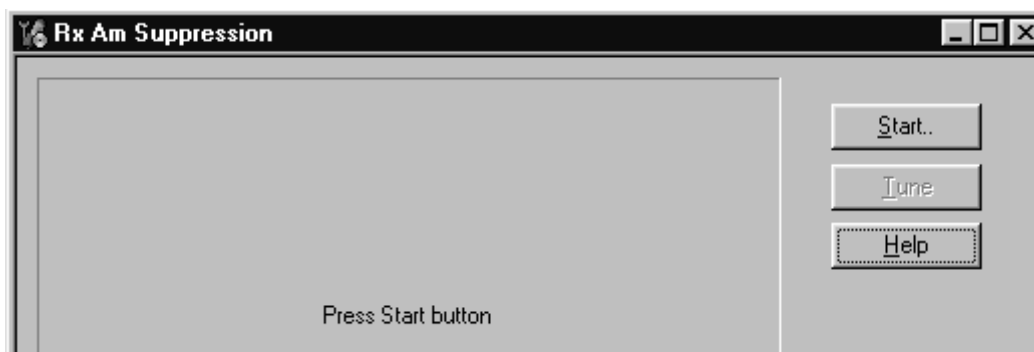

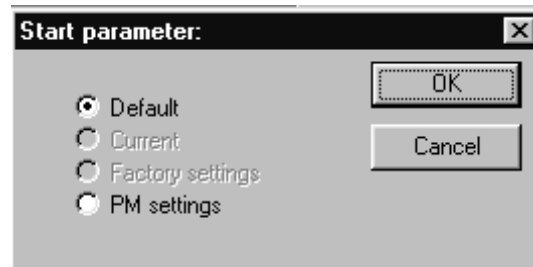

- Set RF generator to state described in left-side window.
- Set the Tuning mode to "Automatic"
- Press the "Tune" button to perform actual tuning.
- The new tuning values and Rssi dBm value are updated.

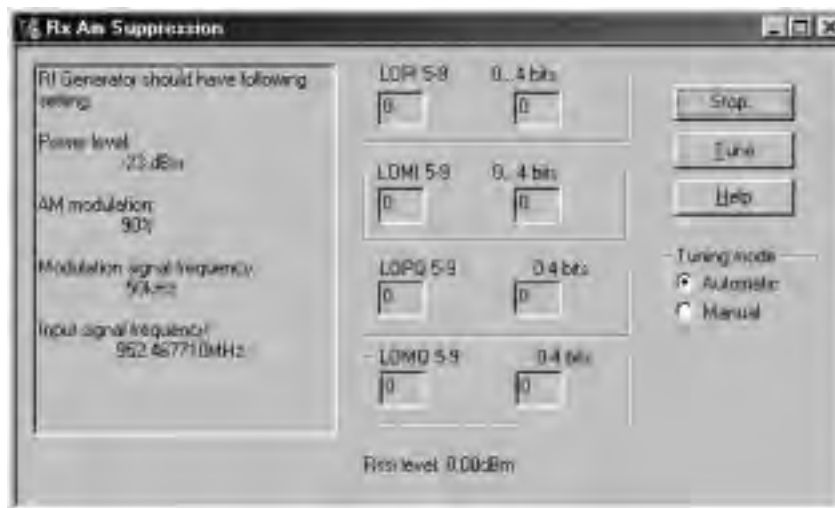

- One "I" and "Q" line values should be 0, other values 0..31
- RSSI level should be around -107 dBm

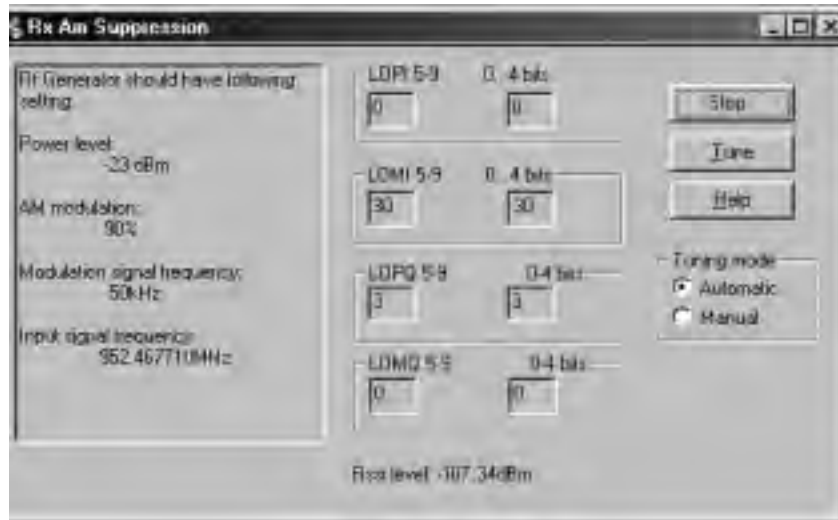

- If values shown are within limits, Select “Stop”
- Choose “Yes” to save values to the phone

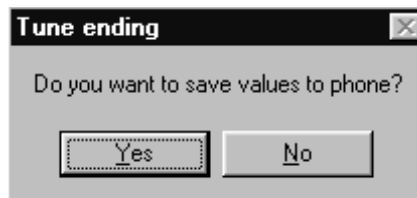

- **Continue tuning from GSM1800.** Choose the correct band from the dropdown menu.

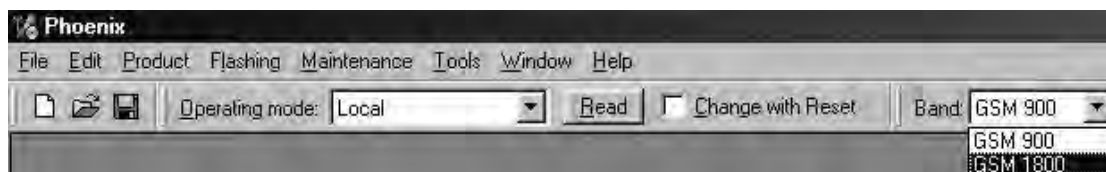

- Repeat the same steps as for the EGSM900 band
- If values shown are within limits, choose “Yes” to save values to the phone
- Close the “RX AM Suppression” – dialog to end tuning

Transmitter Tunings

TX I/Q Tuning

- Spectrum analyzer needed
- Tx IQ Tuning allows changing the Tx I DC Offset, Tx Q DC Offset, Amplitude difference and Phase difference
- Must be done separately on both bands!
- Start TX I/Q Tuning at EGSM (GSM900), then continue at GSM1800 band.
- Remember to take jig and cable attenuations into account!
- Select Maintenance => Tuning => Tx_IQTuning

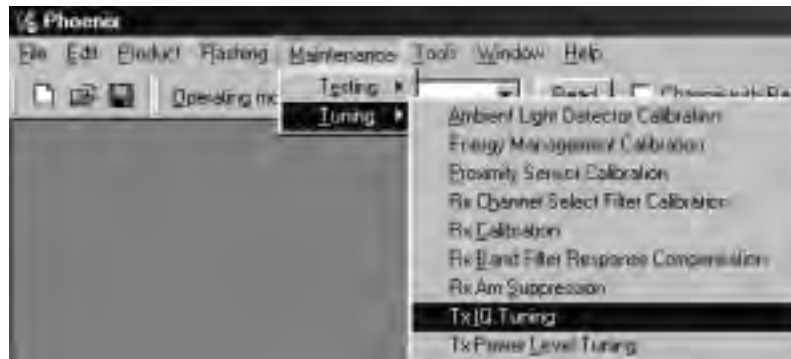

- Select "Load from product" => Start
- The tuning is done by setting each of the sliders to desired value. The sliders can be changed only when the tuning is ongoing.
- The order of tuning should be same as the order of the sliders e.g. the Tx I DC Offset is tuned first and Phase difference is tuned last.
- Use <=, =>, PgUp or PgDn keys

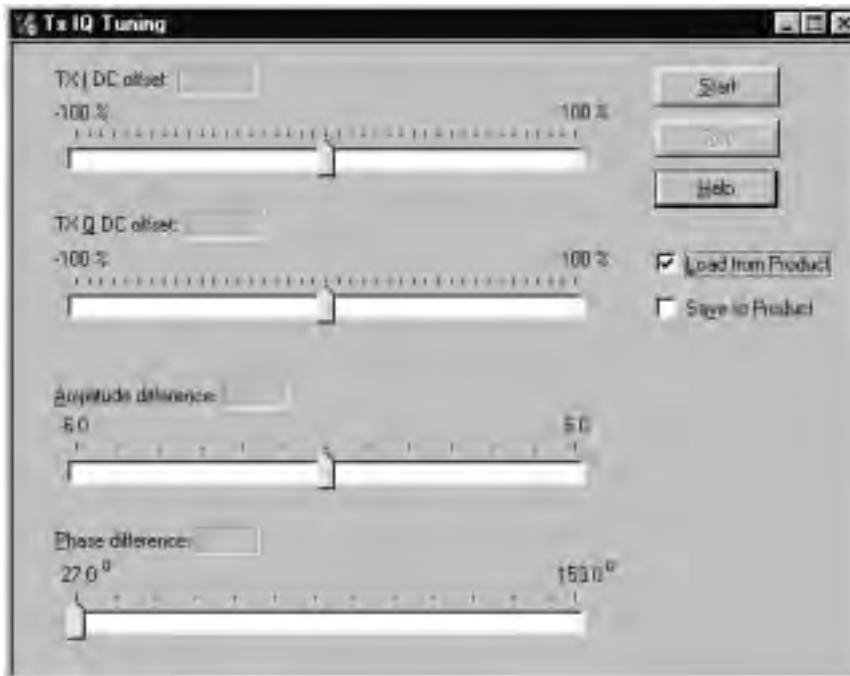

- Set spectrum analyzer center frequency to 897.4 MHz, span 200kHz, RBW and VWB 3kHz and sweptime to 2 seconds
- Tune LO leak to minimum with TXI/TXQ DC offset control (**f0 on spectrum analyzer screen**)
- Tune wrong sideband to minimum using Amplitude/Phase difference controls (**f0+68kHz on spectrum analyzer screen**)

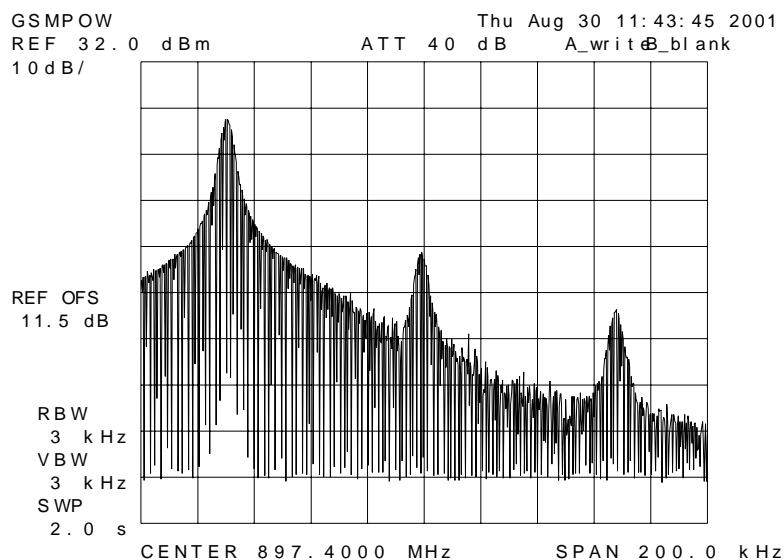

Typical TX Iq Tuning Values and tuning limits GSM 900:

I DC Offset	-2.5...+0.5	-6...+6
Q DC Offset	-2.5...+0.5	-6...+6
Amplitude difference	-0.2...+0.2	-1...+1
Phase difference	88.0°....92.0°	80°...100°

- If values shown are within limits, check the "Save to product" tick box and choose "Stop" save the new values to the product

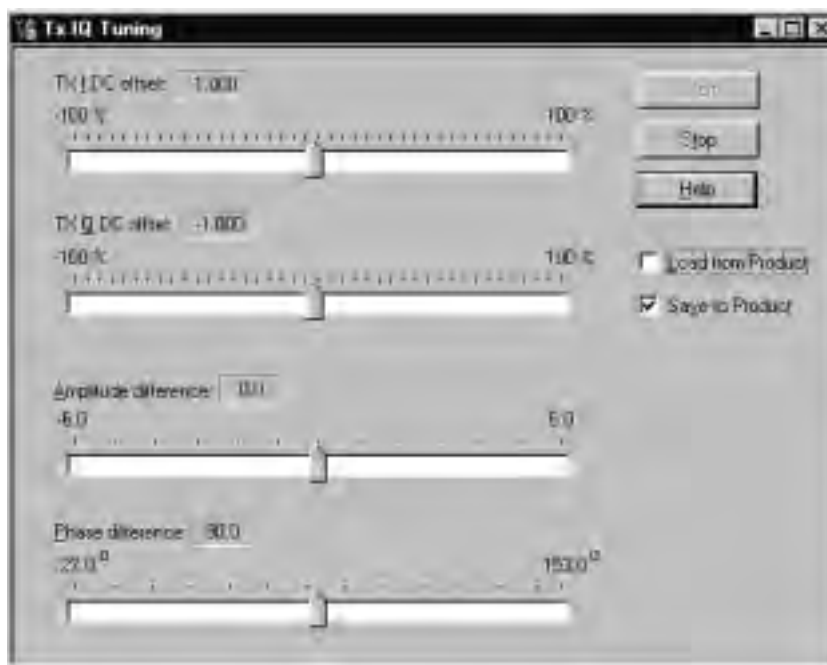

- **Continue tuning from GSM1800.** Choose the correct band from the dropdown menu.

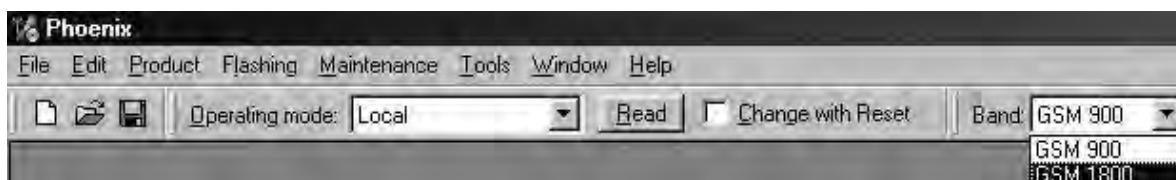

- Repeat the same steps as for the EGSM900 band
- Set spectrum analyzer center frequency to 1747.8 MHz, span 200kHz, RBW and VWB 3kHz and sweep time to 2 seconds

Typical TX IQ Tuning Values and tuning limits GSM1800:

I DC Offset	-3.0...0.0	-6...+6
Q DC Offset	-1.5...+1.0	-6...+6
Amplitude difference	-0.5...+0.0	-1...+1
Phase difference	90.0° ...97.0°	80°...100°

- If values shown are within limits, check the "Save to product" tick box and choose "Stop" save the new values to the product
- Close the "TX I/Q Tuning" – dialog to end tuning

TX Power Level Tuning

- Power Meter with peak power sensor (or Spectrum analyzer) needed
- With Tx Power Level Tuning, the coefficients are adjusted for each power level
- Must be done separately on both bands!
- Start Power Level tuning at EGSM (GSM900), then continue at GSM1800 band.
- In EGSM900 band The power level tuning is made for both high and low PA Modes
- In GSM1800 band only for high PA mode.
- Maintenance => Tuning => Tx power level tuning
- Remember to take jig and cable attenuations into account!

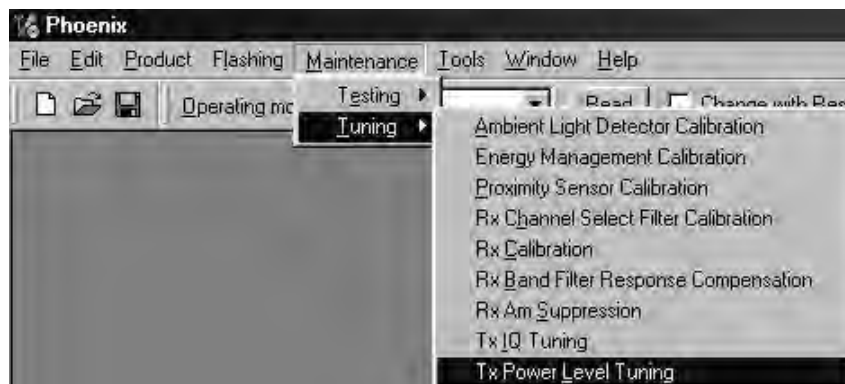

- Select "Start" => "Load from: Permanent memory" => "OK "
- *Note that TX PA mode is "High" at this point.*

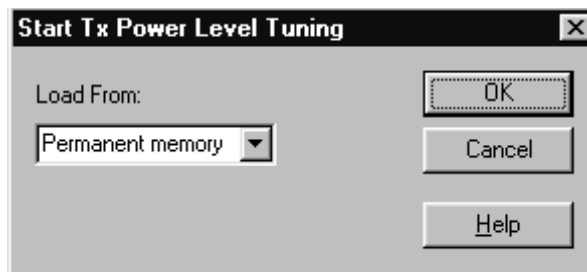
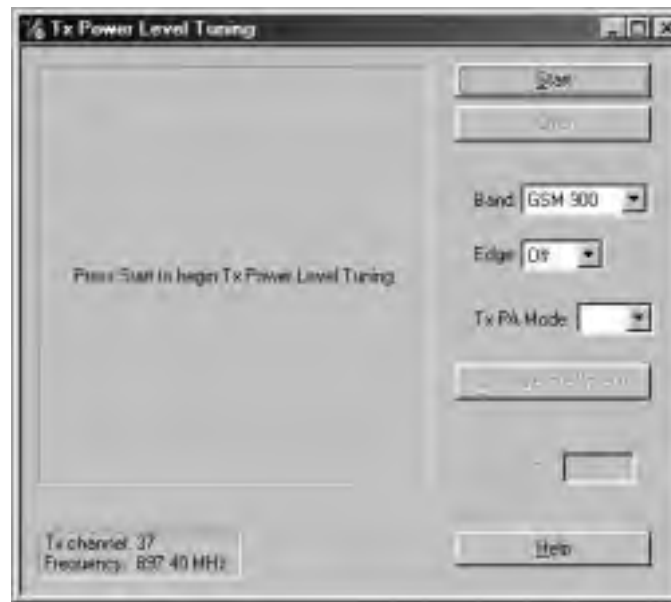

- The coefficient table lists the power level, coefficient, target dBm and DAC value for each power level.
- The tuned power level can be chosen by using up and down arrows or mouse.
- The current power level is shown with inverse colors.
- The tuning value can be adjusted with "-" and "+" keys
- **Tune base level and power levels 19,15 and 5 to target level**
- Press "Calculate coefficients"
- **Change TxPA Mode to "Low"** from the drop down menu. When the PA Mode is changed, the previous values are saved in memory and the ones for new mode are shown

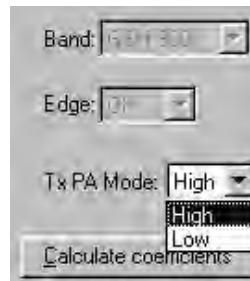

- Tune power levels **19**, **15** and **7** (Levels 5 & 6 are not used, base level tuning not needed)
- Press "Calculate coefficients"

Typical values: EGSM900

Power level	PA high mode	PA low mode
5	0.700...0.750	-
7	-	0.530...0.570
15	0.190...0.210	0.190...0.210
19	0.170...0.180	0.170...0.180
Base	0.140...0.150	0.140...0.150

- If values shown are within limits select "Stop" and check "Save values to phone permanent memory"
- Select "Yes" to save values to phone

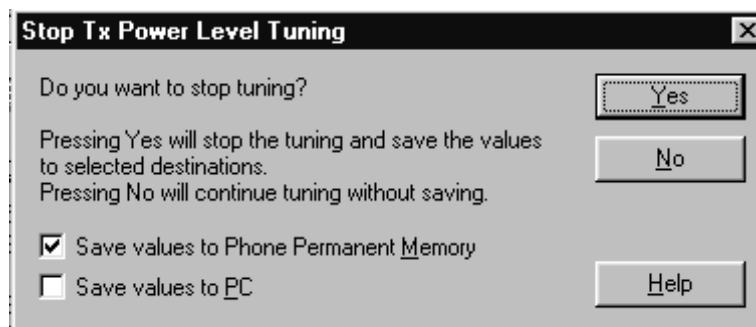

- Continue tuning from **GSM1800**. Choose the correct band from the dropdown menu.

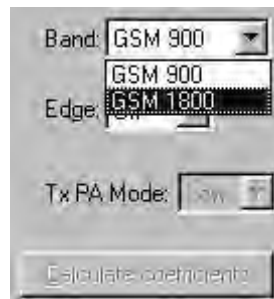

- Repeat the same steps as for the EGSM900 band above
- Note that In GSM1800 band PA mode can not be changed because tuning is only made in "High" mode



Typical values: GSM1800

Power level	PA high mode
0	0.620...0.670
11	0.170...0.190
15	0.150...0.170
Base	0.140...0.150

- If values shown are within limits select "Stop" and check "Save values to phone permanent memory"
- Select "Yes" to save values to phone
- Close the "TX Power Level Tuning" – dialog to end tuning

Appendix

Frequency mappings

The following figure shows the RX/TX operating frequency mapping to the frequency synthesizer operating frequency. For a more detailed list of actual channel number mappings see below.

Figure 14: NHL-2NA VCO frequency mappings

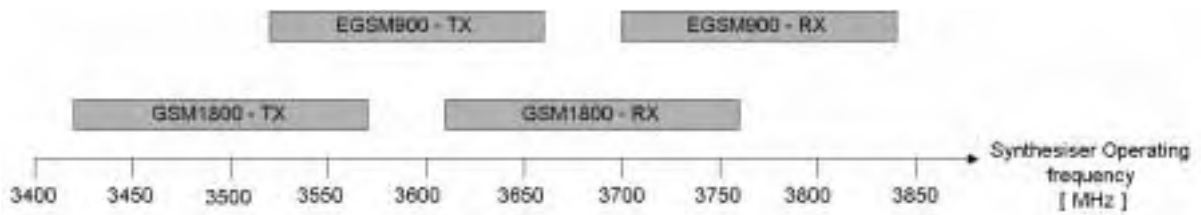

E-GSM900

Table 1: E-GSM900 Channel to VCO operating frequency mapping

Ch	TX	RX	VCO TX	VCO RX	Ch	TX	RX	VCO TX	VCO RX	Ch	TX	RX	VCO TX	VCO RX
975	880.2	925.2	3520.8	3700.8	1	890.2	935.2	3560.8	3740.8	63	902.6	947.6	3610.4	3790.4
976	880.4	925.4	3521.6	3701.6	2	890.4	935.4	3561.6	3741.6	64	902.8	947.8	3611.2	3791.2
977	880.6	925.6	3522.4	3702.4	3	890.6	935.6	3562.4	3742.4	65	903	948	3612	3792
978	880.8	925.8	3523.2	3703.2	4	890.8	935.8	3563.2	3743.2	66	903.2	948.2	3612.8	3792.8
979	881	926	3524	3704	5	891	936	3564	3744	67	903.4	948.4	3613.6	3793.6
980	881.2	926.2	3524.8	3704.8	6	891.2	936.2	3564.8	3744.8	68	903.6	948.6	3614.4	3794.4
981	881.4	926.4	3525.6	3705.6	7	891.4	936.4	3565.6	3745.6	69	903.8	948.8	3615.2	3795.2
982	881.6	926.6	3526.4	3706.4	8	891.6	936.6	3566.4	3746.4	70	904	949	3616	3796
983	881.8	926.8	3527.2	3707.2	9	891.8	936.8	3567.2	3747.2	71	904.2	949.2	3616.8	3796.8
984	882	927	3528	3708	10	892	937	3568	3748	72	904.4	949.4	3617.6	3797.6
985	882.2	927.2	3528.8	3708.8	11	892.2	937.2	3568.8	3748.8	73	904.6	949.6	3618.4	3798.4
986	882.4	927.4	3529.6	3709.6	12	892.4	937.4	3569.6	3749.6	74	904.8	949.8	3619.2	3799.2
987	882.6	927.6	3530.4	3710.4	13	892.6	937.6	3570.4	3750.4	75	905	950	3620	3800
988	882.8	927.8	3531.2	3711.2	14	892.8	937.8	3571.2	3751.2	76	905.2	950.2	3620.8	3800.8
989	883	928	3532	3712	15	893	938	3572	3752	77	905.4	950.4	3621.6	3801.6
990	883.2	928.2	3532.8	3712.8	16	893.2	938.2	3572.8	3752.8	78	905.6	950.6	3622.4	3802.4
991	883.4	928.4	3533.6	3713.6	17	893.4	938.4	3573.6	3753.6	79	905.8	950.8	3623.2	3803.2
992	883.6	928.6	3534.4	3714.4	18	893.6	938.6	3574.4	3754.4	80	906	951	3624	3804
993	883.8	928.8	3535.2	3715.2	19	893.8	938.8	3575.2	3755.2	81	906.2	951.2	3624.8	3804.8
994	884	929	3536	3716	20	894	939	3576	3756	82	906.4	951.4	3625.6	3805.6
995	884.2	929.2	3536.8	3716.8	21	894.2	939.2	3576.8	3756.8	83	906.6	951.6	3626.4	3806.4
996	884.4	929.4	3537.6	3717.6	22	894.4	939.4	3577.6	3757.6	84	906.8	951.8	3627.2	3807.2
997	884.6	929.6	3538.4	3718.4	23	894.6	939.6	3578.4	3758.4	85	907	952	3628	3808
998	884.8	929.8	3539.2	3719.2	24	894.8	939.8	3579.2	3759.2	86	907.2	952.2	3628.8	3808.8
999	885	930	3540	3720	25	895	940	3580	3760	87	907.4	952.4	3629.6	3809.6

1000	885.2	930.2	3540.8	3720.8	26	895.2	940.2	3580.8	3760.8	88	907.6	952.6	3630.4	3810.4
1001	885.4	930.4	3541.6	3721.6	27	895.4	940.4	3581.6	3761.6	89	907.8	952.8	3631.2	3811.2
1002	885.6	930.6	3542.4	3722.4	28	895.6	940.6	3582.4	3762.4	90	908	953	3632	3812
1003	885.8	930.8	3543.2	3723.2	29	895.8	940.8	3583.2	3763.2	91	908.2	953.2	3632.8	3812.8
1004	886	931	3544	3724	30	896	941	3584	3764	92	908.4	953.4	3633.6	3813.6
1005	886.2	931.2	3544.8	3724.8	31	896.2	941.2	3584.8	3764.8	93	908.6	953.6	3634.4	3814.4
1006	886.4	931.4	3545.6	3725.6	32	896.4	941.4	3585.6	3765.6	94	908.8	953.8	3635.2	3815.2
1007	886.6	931.6	3546.4	3726.4	33	896.6	941.6	3586.4	3766.4	95	909	954	3636	3816
1008	886.8	931.8	3547.2	3727.2	34	896.8	941.8	3587.2	3767.2	96	909.2	954.2	3636.8	3816.8
1009	887	932	3548	3728	35	897	942	3588	3768	97	909.4	954.4	3637.6	3817.6
1010	887.2	932.2	3548.8	3728.8	36	897.2	942.2	3588.8	3768.8	98	909.6	954.6	3638.4	3818.4
1011	887.4	932.4	3549.6	3729.6	37	897.4	942.4	3589.6	3769.6	99	909.8	954.8	3639.2	3819.2
1012	887.6	932.6	3550.4	3730.4	38	897.6	942.6	3590.4	3770.4	100	910	955	3640	3820
1013	887.8	932.8	3551.2	3731.2	39	897.8	942.8	3591.2	3771.2	101	910.2	955.2	3640.8	3820.8
1014	888	933	3552	3732	40	898	943	3592	3772	102	910.4	955.4	3641.6	3821.6
1015	888.2	933.2	3552.8	3732.8	41	898.2	943.2	3592.8	3772.8	103	910.6	955.6	3642.4	3822.4
1016	888.4	933.4	3553.6	3733.6	42	898.4	943.4	3593.6	3773.6	104	910.8	955.8	3643.2	3823.2
1017	888.6	933.6	3554.4	3734.4	43	898.6	943.6	3594.4	3774.4	105	911	956	3644	3824
1018	888.8	933.8	3555.2	3735.2	44	898.8	943.8	3595.2	3775.2	106	911.2	956.2	3644.8	3824.8
1019	889	934	3556	3736	45	899	944	3596	3776	107	911.4	956.4	3645.6	3825.6
1020	889.2	934.2	3556.8	3736.8	46	899.2	944.2	3596.8	3776.8	108	911.6	956.6	3646.4	3826.4
1021	889.4	934.4	3557.6	3737.6	47	899.4	944.4	3597.6	3777.6	109	911.8	956.8	3647.2	3827.2
1022	889.6	934.6	3558.4	3738.4	48	899.6	944.6	3598.4	3778.4	110	912	957	3648	3828
1023	889.8	934.8	3559.2	3739.2	49	899.8	944.8	3599.2	3779.2	111	912.2	957.2	3648.8	3828.8
0	890	935	3560	3740	50	900	945	3600	3780	112	912.4	957.4	3649.6	3829.6
					51	900.2	945.2	3600.8	3780.8	113	912.6	957.6	3650.4	3830.4
					52	900.4	945.4	3601.6	3781.6	114	912.8	957.8	3651.2	3831.2

	53	900.6	945.6	3602.4	3782.4	115	913	958	3652	3832
	54	900.8	945.8	3603.2	3783.2	116	913.2	958.2	3652.8	3832.8
	55	901	946	3604	3784	117	913.4	958.4	3653.6	3833.6
	56	901.2	946.2	3604.8	3784.8	118	913.6	958.6	3654.4	3834.4
	57	901.4	946.4	3605.6	3785.6	119	913.8	958.8	3655.2	3835.2
	58	901.6	946.6	3606.4	3786.4	120	914	959	3656	3836
	59	901.8	946.8	3607.2	3787.2	121	914.2	959.2	3656.8	3836.8
	60	902	947	3608	3788	122	914.4	959.4	3657.6	3837.6
	61	902.2	947.2	3608.8	3788.8	123	914.6	959.6	3658.4	3838.4
	62	902.4	947.4	3609.6	3789.6	124	914.8	959.8	3659.2	3839.2

GSM1800

Table 2: GSM1800 Channel to VCO operating frequency mapping

Ch	TX	RX	VCO TX	VCO RX	Ch	TX	RX	VCO TX	VCO RX	Ch	TX	RX	VCO TX	VCO RX
512	1710.2	1805.2	3420.4	3610.4	638	1735.4	1830.4	3470.8	3660.8	764	1760.6	1855.6	3521.2	3711.2
513	1710.4	1805.4	6841.6	7221.6	639	1735.6	1830.6	3471.2	3661.2	765	1760.8	1855.8	3521.6	3711.6
514	1710.6	1805.6	6842.4	7222.4	640	1735.8	1830.8	3471.6	3661.6	766	1761	1856	3522	3712
515	1710.8	1805.8	6843.2	7223.2	641	1736	1831	3472	3662	767	1761.2	1856.2	3522.4	3712.4
516	1711	1806	6844	7224	642	1736.2	1831.2	3472.4	3662.4	768	1761.4	1856.4	3522.8	3712.8
517	1711.2	1806.2	6844.8	7224.8	643	1736.4	1831.4	3472.8	3662.8	769	1761.6	1856.6	3523.2	3713.2
518	1711.4	1806.4	6845.6	7225.6	644	1736.6	1831.6	3473.2	3663.2	770	1761.8	1856.8	3523.6	3713.6
519	1711.6	1806.6	6846.4	7226.4	645	1736.8	1831.8	3473.6	3663.6	771	1762	1857	3524	3714
520	1711.8	1806.8	6847.2	7227.2	646	1737	1832	3474	3664	772	1762.2	1857.2	3524.4	3714.4
521	1712	1807	6848	7228	647	1737.2	1832.2	3474.4	3664.4	773	1762.4	1857.4	3524.8	3714.8
522	1712.2	1807.2	6848.8	7228.8	648	1737.4	1832.4	3474.8	3664.8	774	1762.6	1857.6	3525.2	3715.2
523	1712.4	1807.4	6849.6	7229.6	649	1737.6	1832.6	3475.2	3665.2	775	1762.8	1857.8	3525.6	3715.6
524	1712.6	1807.6	6850.4	7230.4	650	1737.8	1832.8	3475.6	3665.6	776	1763	1858	3526	3716
525	1712.8	1807.8	6851.2	7231.2	651	1738	1833	3476	3666	777	1763.2	1858.2	3526.4	3716.4

526	1713	1808	6852	7232	652	1738. 2	1833. 2	3476. 4	3666. 4	778	1763. 4	1858. 4	3526. 8	3716. 8
527	1713. 2	1808. 2	6852. 8	7232. 8	653	1738. 4	1833. 4	3476. 8	3666. 8	779	1763. 6	1858. 6	3527. 2	3717. 2
528	1713. 4	1808. 4	6853. 6	7233. 6	654	1738. 6	1833. 6	3477. 2	3667. 2	780	1763. 8	1858. 8	3527. 6	3717. 6
529	1713. 6	1808. 6	6854. 4	7234. 4	655	1738. 8	1833. 8	3477. 6	3667. 6	781	1764	1859	3528	3718
530	1713. 8	1808. 8	6855. 2	7235. 2	656	1739	1834	3478	3668	782	1764. 2	1859. 2	3528. 4	3718. 4
531	1714	1809	6856	7236	657	1739. 2	1834. 2	3478. 4	3668. 4	783	1764. 4	1859. 4	3528. 8	3718. 8
532	1714. 2	1809. 2	6856. 8	7236. 8	658	1739. 4	1834. 4	3478. 8	3668. 8	784	1764. 6	1859. 6	3529. 2	3719. 2
533	1714. 4	1809. 4	6857. 6	7237. 6	659	1739. 6	1834. 6	3479. 2	3669. 2	785	1764. 8	1859. 8	3529. 6	3719. 6
534	1714. 6	1809. 6	6858. 4	7238. 4	660	1739. 8	1834. 8	3479. 6	3669. 6	786	1765	1860	3530	3720
535	1714. 8	1809. 8	6859. 2	7239. 2	661	1740	1835	3480	3670	787	1765. 2	1860. 2	3530. 4	3720. 4
536	1715	1810	6860	7240	662	1740. 2	1835. 2	3480. 4	3670. 4	788	1765. 4	1860. 4	3530. 8	3720. 8
537	1715. 2	1810. 2	6860. 8	7240. 8	663	1740. 4	1835. 4	3480. 8	3670. 8	789	1765. 6	1860. 6	3531. 2	3721. 2
538	1715. 4	1810. 4	6861. 6	7241. 6	664	1740. 6	1835. 6	3481. 2	3671. 2	790	1765. 8	1860. 8	3531. 6	3721. 6
539	1715. 6	1810. 6	6862. 4	7242. 4	665	1740. 8	1835. 8	3481. 6	3671. 6	791	1766	1861	3532	3722
540	1715. 8	1810. 8	6863. 2	7243. 2	666	1741	1836	3482	3672	792	1766. 2	1861. 2	3532. 4	3722. 4
541	1716	1811	6864	7244	667	1741. 2	1836. 2	3482. 4	3672. 4	793	1766. 4	1861. 4	3532. 8	3722. 8
542	1716. 2	1811. 2	6864. 8	7244. 8	668	1741. 4	1836. 4	3482. 8	3672. 8	794	1766. 6	1861. 6	3533. 2	3723. 2
543	1716. 4	1811. 4	6865. 6	7245. 6	669	1741. 6	1836. 6	3483. 2	3673. 2	795	1766. 8	1861. 8	3533. 6	3723. 6
544	1716. 6	1811. 6	6866. 4	7246. 4	670	1741. 8	1836. 8	3483. 6	3673. 6	796	1767	1862	3534	3724
545	1716. 8	1811. 8	6867. 2	7247. 2	671	1742	1837	3484	3674	797	1767. 2	1862. 2	3534. 4	3724. 4
546	1717	1812	6868	7248	672	1742. 2	1837. 2	3484. 4	3674. 4	798	1767. 4	1862. 4	3534. 8	3724. 8
547	1717. 2	1812. 2	6868. 8	7248. 8	673	1742. 4	1837. 4	3484. 8	3674. 8	799	1767. 6	1862. 6	3535. 2	3725. 2
548	1717. 4	1812. 4	6869. 6	7249. 6	674	1742. 6	1837. 6	3485. 2	3675. 2	800	1767. 8	1862. 8	3535. 6	3725. 6
549	1717. 6	1812. 6	6870. 4	7250. 4	675	1742. 8	1837. 8	3485. 6	3675. 6	801	1768	1863	3536	3726
550	1717. 8	1812. 8	6871. 2	7251. 2	676	1743	1838	3486	3676	802	1768. 2	1863. 2	3536. 4	3726. 4
551	1718	1813	6872	7252	677	1743. 2	1838. 2	3486. 4	3676. 4	803	1768. 4	1863. 4	3536. 8	3726. 8
552	1718. 2	1813. 2	6872. 8	7252. 8	678	1743. 4	1838. 4	3486. 8	3676. 8	804	1768. 6	1863. 6	3537. 2	3727. 2

553	1718. 4	1813. 4	6873. 6	7253. 6	679	1743. 6	1838. 6	3487. 2	3677. 2	805	1768. 8	1863. 8	3537. 6	3727. 6
554	1718. 6	1813. 6	6874. 4	7254. 4	680	1743. 8	1838. 8	3487. 6	3677. 6	806	1769	1864	3538	3728
555	1718. 8	1813. 8	6875. 2	7255. 2	681	1744	1839	3488	3678	807	1769. 2	1864. 2	3538. 4	3728. 4
556	1719	1814	6876	7256	682	1744. 2	1839. 2	3488. 4	3678. 4	808	1769. 4	1864. 4	3538. 8	3728. 8
557	1719. 2	1814. 2	6876. 8	7256. 8	683	1744. 4	1839. 4	3488. 8	3678. 8	809	1769. 6	1864. 6	3539. 2	3729. 2
558	1719. 4	1814. 4	6877. 6	7257. 6	684	1744. 6	1839. 6	3489. 2	3679. 2	810	1769. 8	1864. 8	3539. 6	3729. 6
559	1719. 6	1814. 6	6878. 4	7258. 4	685	1744. 8	1839. 8	3489. 6	3679. 6	811	1770	1865	3540	3730
560	1719. 8	1814. 8	6879. 2	7259. 2	686	1745	1840	3490	3680	812	1770. 2	1865. 2	3540. 4	3730. 4
561	1720	1815	6880	7260	687	1745. 2	1840. 2	3490. 4	3680. 4	813	1770. 4	1865. 4	3540. 8	3730. 8
562	1720. 2	1815. 2	6880. 8	7260. 8	688	1745. 4	1840. 4	3490. 8	3680. 8	814	1770. 6	1865. 6	3541. 2	3731. 2
563	1720. 4	1815. 4	6881. 6	7261. 6	689	1745. 6	1840. 6	3491. 2	3681. 2	815	1770. 8	1865. 8	3541. 6	3731. 6
564	1720. 6	1815. 6	6882. 4	7262. 4	690	1745. 8	1840. 8	3491. 6	3681. 6	816	1771	1866	3542	3732
565	1720. 8	1815. 8	6883. 2	7263. 2	691	1746	1841	3492	3682	817	1771. 2	1866. 2	3542. 4	3732. 4
566	1721	1816	6884	7264	692	1746. 2	1841. 2	3492. 4	3682. 4	818	1771. 4	1866. 4	3542. 8	3732. 8
567	1721. 2	1816. 2	6884. 8	7264. 8	693	1746. 4	1841. 4	3492. 8	3682. 8	819	1771. 6	1866. 6	3543. 2	3733. 2
568	1721. 4	1816. 4	6885. 6	7265. 6	694	1746. 6	1841. 6	3493. 2	3683. 2	820	1771. 8	1866. 8	3543. 6	3733. 6
569	1721. 6	1816. 6	6886. 4	7266. 4	695	1746. 8	1841. 8	3493. 6	3683. 6	821	1772	1867	3544	3734
570	1721. 8	1816. 8	6887. 2	7267. 2	696	1747	1842	3494	3684	822	1772. 2	1867. 2	3544. 4	3734. 4
571	1722	1817	6888	7268	697	1747. 2	1842. 2	3494. 4	3684. 4	823	1772. 4	1867. 4	3544. 8	3734. 8
572	1722. 2	1817. 2	6888. 8	7268. 8	698	1747. 4	1842. 4	3494. 8	3684. 8	824	1772. 6	1867. 6	3545. 2	3735. 2
573	1722. 4	1817. 4	6889. 6	7269. 6	699	1747. 6	1842. 6	3495. 2	3685. 2	825	1772. 8	1867. 8	3545. 6	3735. 6
574	1722. 6	1817. 6	6890. 4	7270. 4	700	1747. 8	1842. 8	3495. 6	3685. 6	826	1773	1868	3546	3736
575	1722. 8	1817. 8	3445. 6	3635. 6	701	1748	1843	3496	3686	827	1773. 2	1868. 2	3546. 4	3736. 4
576	1723	1818	3446	3636	702	1748. 2	1843. 2	3496. 4	3686. 4	828	1773. 4	1868. 4	3546. 8	3736. 8
577	1723. 2	1818. 2	3446. 4	3636. 4	703	1748. 4	1843. 4	3496. 8	3686. 8	829	1773. 6	1868. 6	3547. 2	3737. 2
578	1723. 4	1818. 4	3446. 8	3636. 8	704	1748. 6	1843. 6	3497. 2	3687. 2	830	1773. 8	1868. 8	3547. 6	3737. 6
579	1723. 6	1818. 6	3447. 2	3637. 2	705	1748. 8	1843. 8	3497. 6	3687. 6	831	1774	1869	3548	3738

580	1723.8	1818.8	3447.6	3637.6	706	1749	1844	3498	3688	832	1774.2	1869.2	3548.4	3738.4
581	1724	1819	3448	3638	707	1749.2	1844.2	3498.4	3688.4	833	1774.4	1869.4	3548.8	3738.8
582	1724.2	1819.2	3448.4	3638.4	708	1749.4	1844.4	3498.8	3688.8	834	1774.6	1869.6	3549.2	3739.2
583	1724.4	1819.4	3448.8	3638.8	709	1749.6	1844.6	3499.2	3689.2	835	1774.8	1869.8	3549.6	3739.6
584	1724.6	1819.6	3449.2	3639.2	710	1749.8	1844.8	3499.6	3689.6	836	1775	1870	3550	3740
585	1724.8	1819.8	3449.6	3639.6	711	1750	1845	3500	3690	837	1775.2	1870.2	3550.4	3740.4
586	1725	1820	3450	3640	712	1750.2	1845.2	3500.4	3690.4	838	1775.4	1870.4	3550.8	3740.8
587	1725.2	1820.2	3450.4	3640.4	713	1750.4	1845.4	3500.8	3690.8	839	1775.6	1870.6	3551.2	3741.2
588	1725.4	1820.4	3450.8	3640.8	714	1750.6	1845.6	3501.2	3691.2	840	1775.8	1870.8	3551.6	3741.6
589	1725.6	1820.6	3451.2	3641.2	715	1750.8	1845.8	3501.6	3691.6	841	1776	1871	3552	3742
590	1725.8	1820.8	3451.6	3641.6	716	1751	1846	3502	3692	842	1776.2	1871.2	3552.4	3742.4
591	1726	1821	3452	3642	717	1751.2	1846.2	3502.4	3692.4	843	1776.4	1871.4	3552.8	3742.8
592	1726.2	1821.2	3452.4	3642.4	718	1751.4	1846.4	3502.8	3692.8	844	1776.6	1871.6	3553.2	3743.2
593	1726.4	1821.4	3452.8	3642.8	719	1751.6	1846.6	3503.2	3693.2	845	1776.8	1871.8	3553.6	3743.6
594	1726.6	1821.6	3453.2	3643.2	720	1751.8	1846.8	3503.6	3693.6	846	1777	1872	3554	3744
595	1726.8	1821.8	3453.6	3643.6	721	1752	1847	3504	3694	847	1777.2	1872.2	3554.4	3744.4
596	1727	1822	3454	3644	722	1752.2	1847.2	3504.4	3694.4	848	1777.4	1872.4	3554.8	3744.8
597	1727.2	1822.2	3454.4	3644.4	723	1752.4	1847.4	3504.8	3694.8	849	1777.6	1872.6	3555.2	3745.2
598	1727.4	1822.4	3454.8	3644.8	724	1752.6	1847.6	3505.2	3695.2	850	1777.8	1872.8	3555.6	3745.6
599	1727.6	1822.6	3455.2	3645.2	725	1752.8	1847.8	3505.6	3695.6	851	1778	1873	3556	3746
600	1727.8	1822.8	3455.6	3645.6	726	1753	1848	3506	3696	852	1778.2	1873.2	3556.4	3746.4
601	1728	1823	3456	3646	727	1753.2	1848.2	3506.4	3696.4	853	1778.4	1873.4	3556.8	3746.8
602	1728.2	1823.2	3456.4	3646.4	728	1753.4	1848.4	3506.8	3696.8	854	1778.6	1873.6	3557.2	3747.2
603	1728.4	1823.4	3456.8	3646.8	729	1753.6	1848.6	3507.2	3697.2	855	1778.8	1873.8	3557.6	3747.6
604	1728.6	1823.6	3457.2	3647.2	730	1753.8	1848.8	3507.6	3697.6	856	1779	1874	3558	3748
605	1728.8	1823.8	3457.6	3647.6	731	1754	1849	3508	3698	857	1779.2	1874.2	3558.4	3748.4
606	1729	1824	3458	3648	732	1754.2	1849.2	3508.4	3698.4	858	1779.4	1874.4	3558.8	3748.8

607	1729.2	1824.2	3458.4	3648.4	733	1754.4	1849.4	3508.8	3698.8	859	1779.6	1874.6	3559.2	3749.2
608	1729.4	1824.4	3458.8	3648.8	734	1754.6	1849.6	3509.2	3699.2	860	1779.8	1874.8	3559.6	3749.6
609	1729.6	1824.6	3459.2	3649.2	735	1754.8	1849.8	3509.6	3699.6	861	1780	1875	3560	3750
610	1729.8	1824.8	3459.6	3649.6	736	1755	1850	3510	3700	862	1780.2	1875.2	3560.4	3750.4
611	1730	1825	3460	3650	737	1755.2	1850.2	3510.4	3700.4	863	1780.4	1875.4	3560.8	3750.8
612	1730.2	1825.2	3460.4	3650.4	738	1755.4	1850.4	3510.8	3700.8	864	1780.6	1875.6	3561.2	3751.2
613	1730.4	1825.4	3460.8	3650.8	739	1755.6	1850.6	3511.2	3701.2	865	1780.8	1875.8	3561.6	3751.6
614	1730.6	1825.6	3461.2	3651.2	740	1755.8	1850.8	3511.6	3701.6	866	1781	1876	3562	3752
615	1730.8	1825.8	3461.6	3651.6	741	1756	1851	3512	3702	867	1781.2	1876.2	3562.4	3752.4
616	1731	1826	3462	3652	742	1756.2	1851.2	3512.4	3702.4	868	1781.4	1876.4	3562.8	3752.8
617	1731.2	1826.2	3462.4	3652.4	743	1756.4	1851.4	3512.8	3702.8	869	1781.6	1876.6	3563.2	3753.2
618	1731.4	1826.4	3462.8	3652.8	744	1756.6	1851.6	3513.2	3703.2	870	1781.8	1876.8	3563.6	3753.6
619	1731.6	1826.6	3463.2	3653.2	745	1756.8	1851.8	3513.6	3703.6	871	1782	1877	3564	3754
620	1731.8	1826.8	3463.6	3653.6	746	1757	1852	3514	3704	872	1782.2	1877.2	3564.4	3754.4
621	1732	1827	3464	3654	747	1757.2	1852.2	3514.4	3704.4	873	1782.4	1877.4	3564.8	3754.8
622	1732.2	1827.2	3464.4	3654.4	748	1757.4	1852.4	3514.8	3704.8	874	1782.6	1877.6	3565.2	3755.2
623	1732.4	1827.4	3464.8	3654.8	749	1757.6	1852.6	3515.2	3705.2	875	1782.8	1877.8	3565.6	3755.6
624	1732.6	1827.6	3465.2	3655.2	750	1757.8	1852.8	3515.6	3705.6	876	1783	1878	3566	3756
625	1732.8	1827.8	3465.6	3655.6	751	1758	1853	3516	3706	877	1783.2	1878.2	3566.4	3756.4
626	1733	1828	3466	3656	752	1758.2	1853.2	3516.4	3706.4	878	1783.4	1878.4	3566.8	3756.8
627	1733.2	1828.2	3466.4	3656.4	753	1758.4	1853.4	3516.8	3706.8	879	1783.6	1878.6	3567.2	3757.2
628	1733.4	1828.4	3466.8	3656.8	754	1758.6	1853.6	3517.2	3707.2	880	1783.8	1878.8	3567.6	3757.6
629	1733.6	1828.6	3467.2	3657.2	755	1758.8	1853.8	3517.6	3707.6	881	1784	1879	3568	3758
630	1733.8	1828.8	3467.6	3657.6	756	1759	1854	3518	3708	882	1784.2	1879.2	3568.4	3758.4
631	1734	1829	3468	3658	757	1759.2	1854.2	3518.4	3708.4	883	1784.4	1879.4	3568.8	3758.8
632	1734.2	1829.2	3468.4	3658.4	758	1759.4	1854.4	3518.8	3708.8	884	1784.6	1879.6	3569.2	3759.2
633	1734.4	1829.4	3468.8	3658.8	759	1759.6	1854.6	3519.2	3709.2	885	1784.8	1879.8	3569.6	3759.6

634	1734. 6	1829. 6	3469. 2	3659. 2	760	1759. 8	1854. 8	3519. 6	3709. 6	
635	1734. 8	1829. 8	3469. 6	3659. 6	761	1760	1855	3520	3710	
636	1735	1830	3470	3660	762	1760. 2	1855. 2	3520. 4	3710. 4	
637	1735. 2	1830. 2	3470. 4	3660. 4	763	1760. 4	1855. 4	3520. 8	3710. 8	

UI Troubleshooting

Introduction

UI module includes LCD display and backlight, four keydomes and a 5-way switch also known as rocker. This document describes it's troubleshooting.

The LCD displays may have bright pixels or dark pixels that are visible with some colors. These are characteristic to active matrix LCD's and do not cause a change of UI module.

Each UI module has a different contrast point. That point can vary more than the end user has possibility to adjust. Therefore every time you change the UI module, you need to adjust the contrast point.

UI module troubleshooting cases

Display blank

There is no image on the display. Display looks the same when the phone is on as it does when the phone is off.

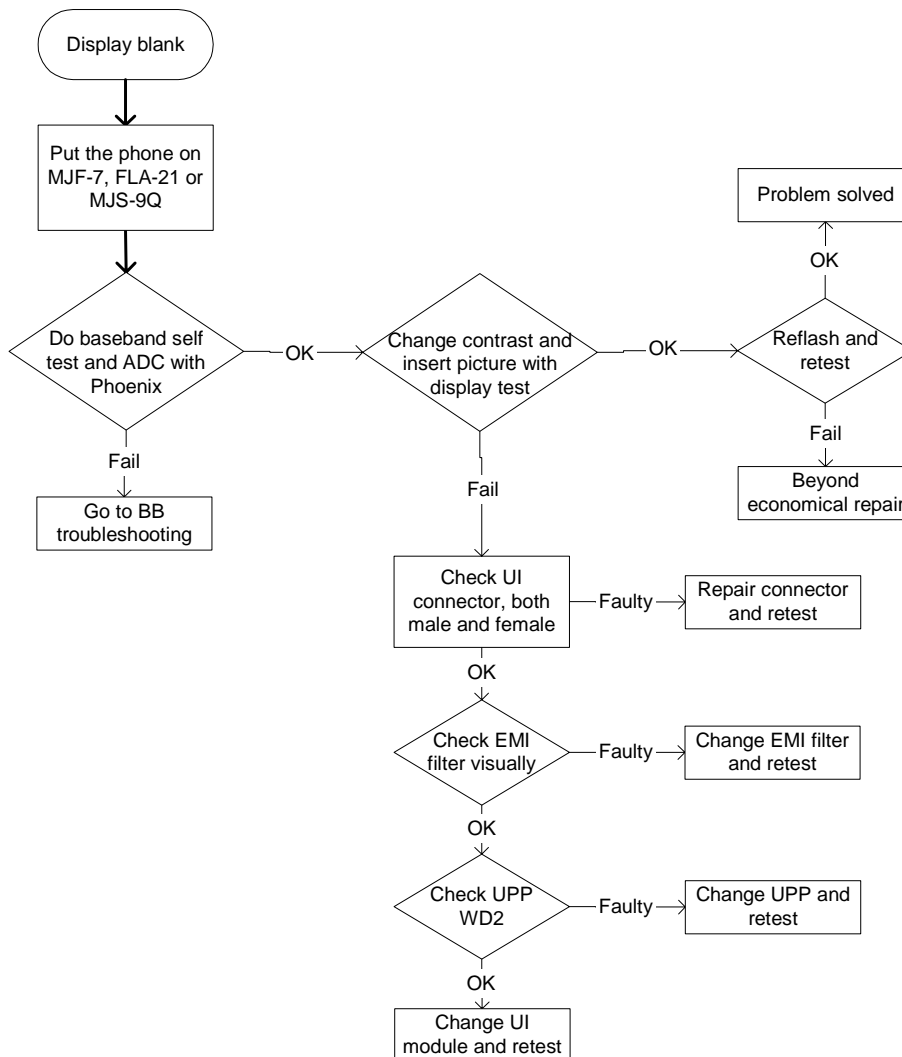
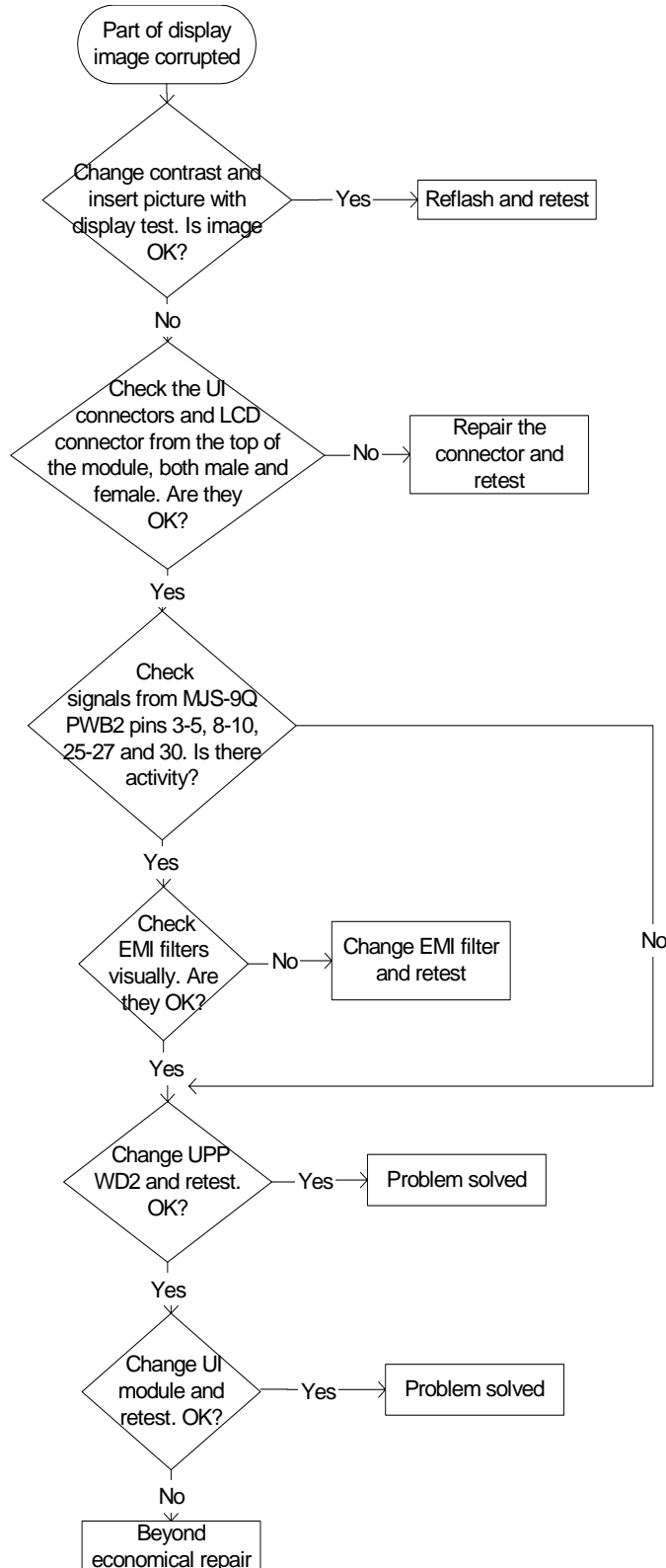

Image on display not correct

Image on the display can be corrupted or part of the image can be missing. If part of image is missing change the UI module. If the image is otherwise corrupted, follow the path below.



This page intentionally left blank.

Key or 5-way switch not working

UI module includes 5-way switch, application key, voice recorder key and two softkeys.

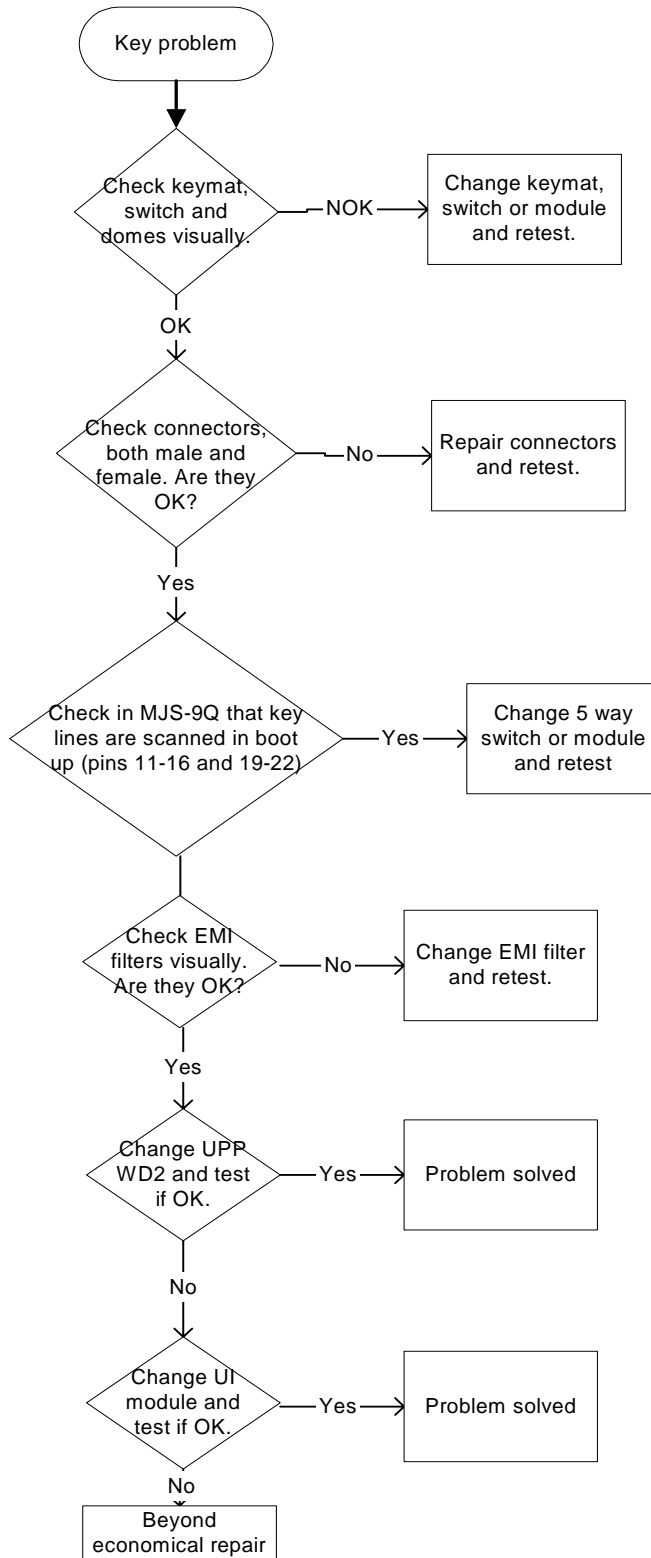

Grip-Module Troubleshooting

Introduction

This section describes how the troubleshooting should be done if there is something wrong with the Nokia 7650 Grip-module (LS4). All parts of the Grip-module - the back-light, current gauge, vibra, keyboard and hall-sensor - have their own flowcharts that describe how problems can be solved. Although the hall-sensor is located in the LG4, its troubleshooting is described in this section.

The following flow charts have some links to each other so they are linked to each other, and in this way, the root cause of a problem can be solved. Please note also that there is a separate troubleshooting section with flowcharts for the transceiver board (LG4).

Backlight

There are basically two kind of problems with the keyboard backlight. The backlight may be dim or there there may be no backlight at all. The following flowchart describes how these two problems can be detected and solved.

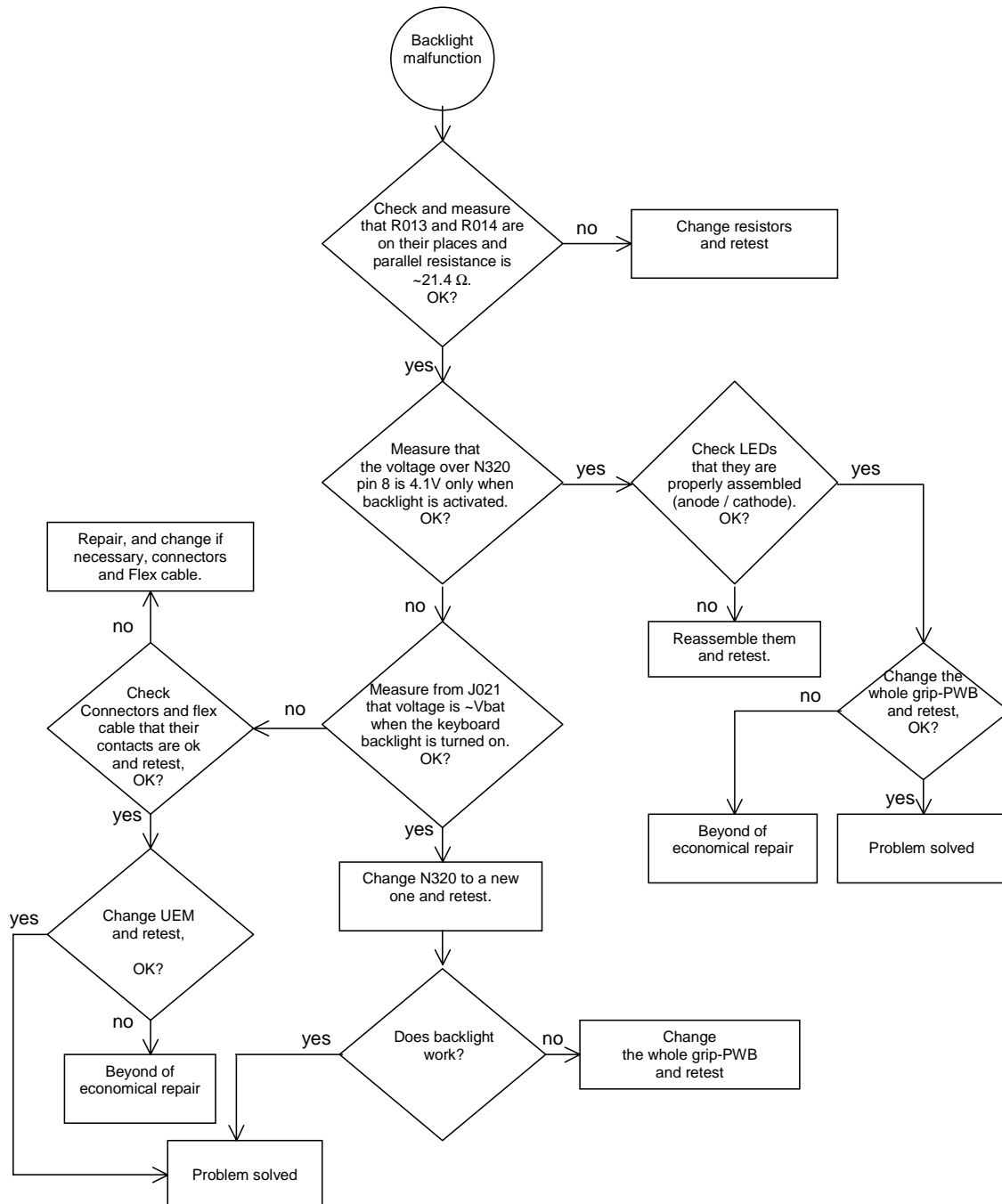

Current Gauge

There are basically three kinds of problems that may occur concerning the current gauge: (1) the PWM signal is out of the specification, (2) it does not give a PWM signal at all or (3) the gauge does not react its shut down signal. The user notices a current gauge problem when the phone never stops charging.

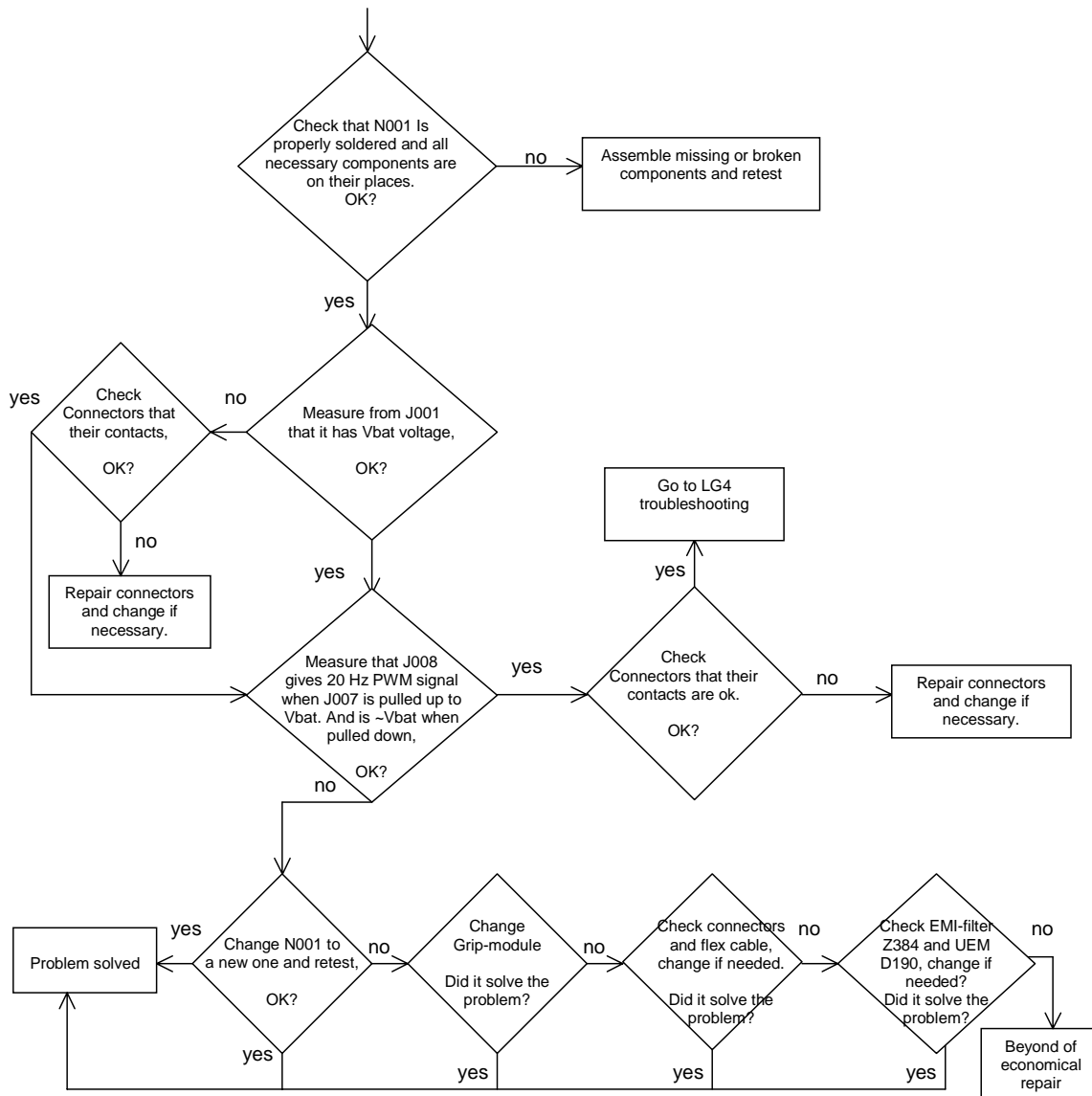

Vibra

There are basically three kind of problems concerning the vibra: (1) it does not rotate at all, (2) it is noisy or (3) it is continuously on. The noisiness is usually caused by the surrounding mechanics when the rotating mass has contact to it.

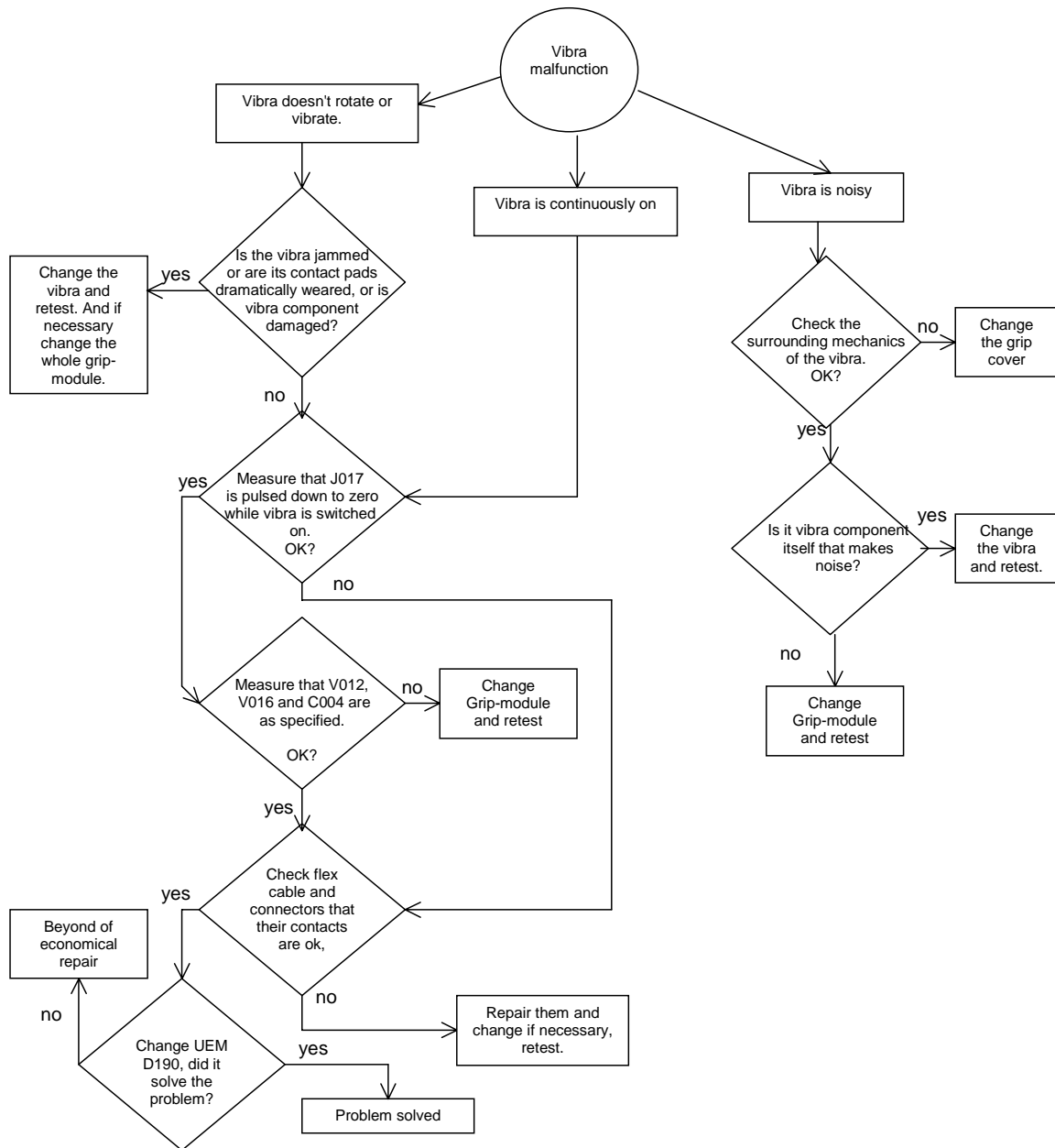

Keyboard

If the Grip keyboard does not work, follow the troubleshooting path in the flowchart below.

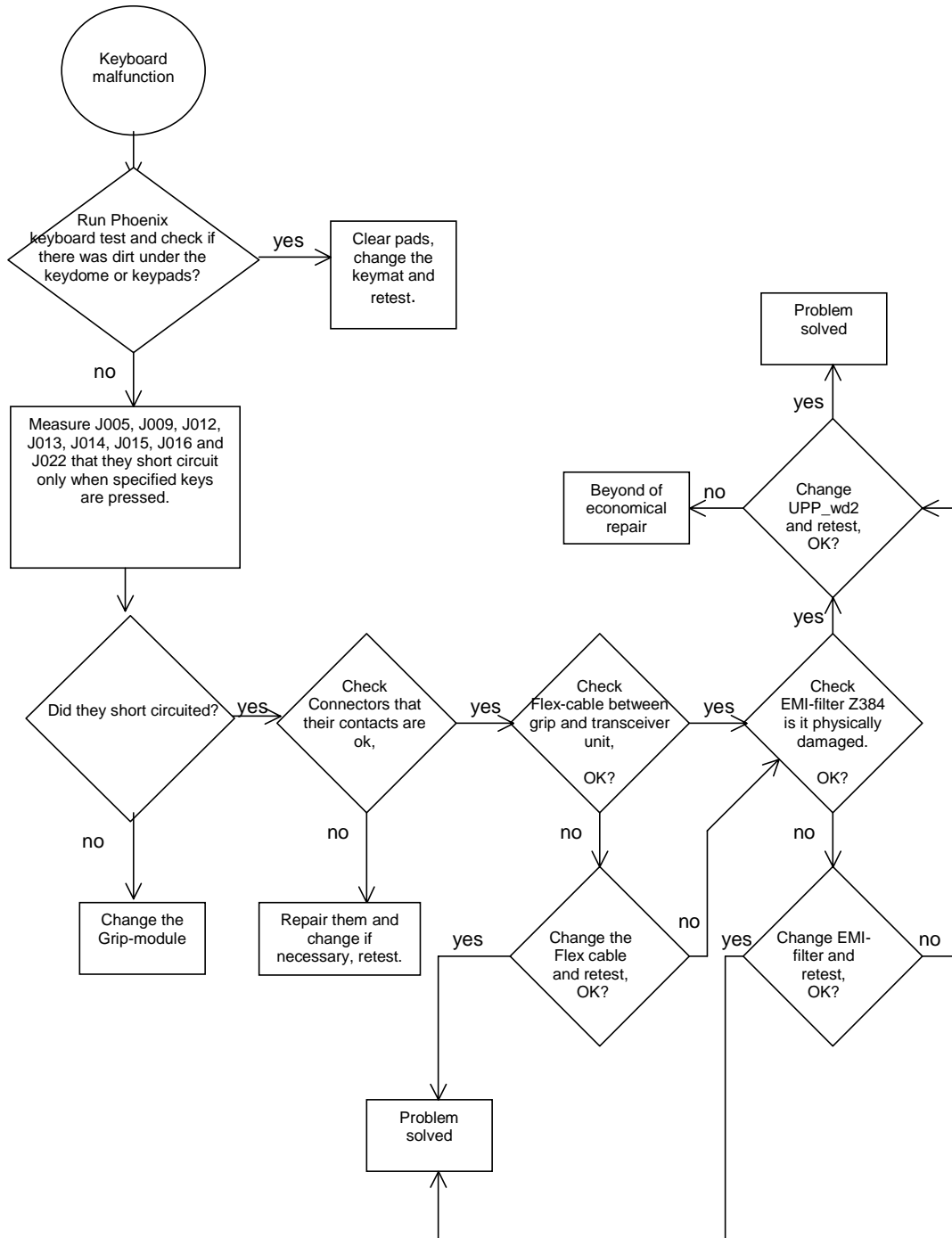

Hall Sensor

There are two possible malfunction concerning the hall sensor: the output of the hall sensor stays on high or low regardless the position of the magnet.

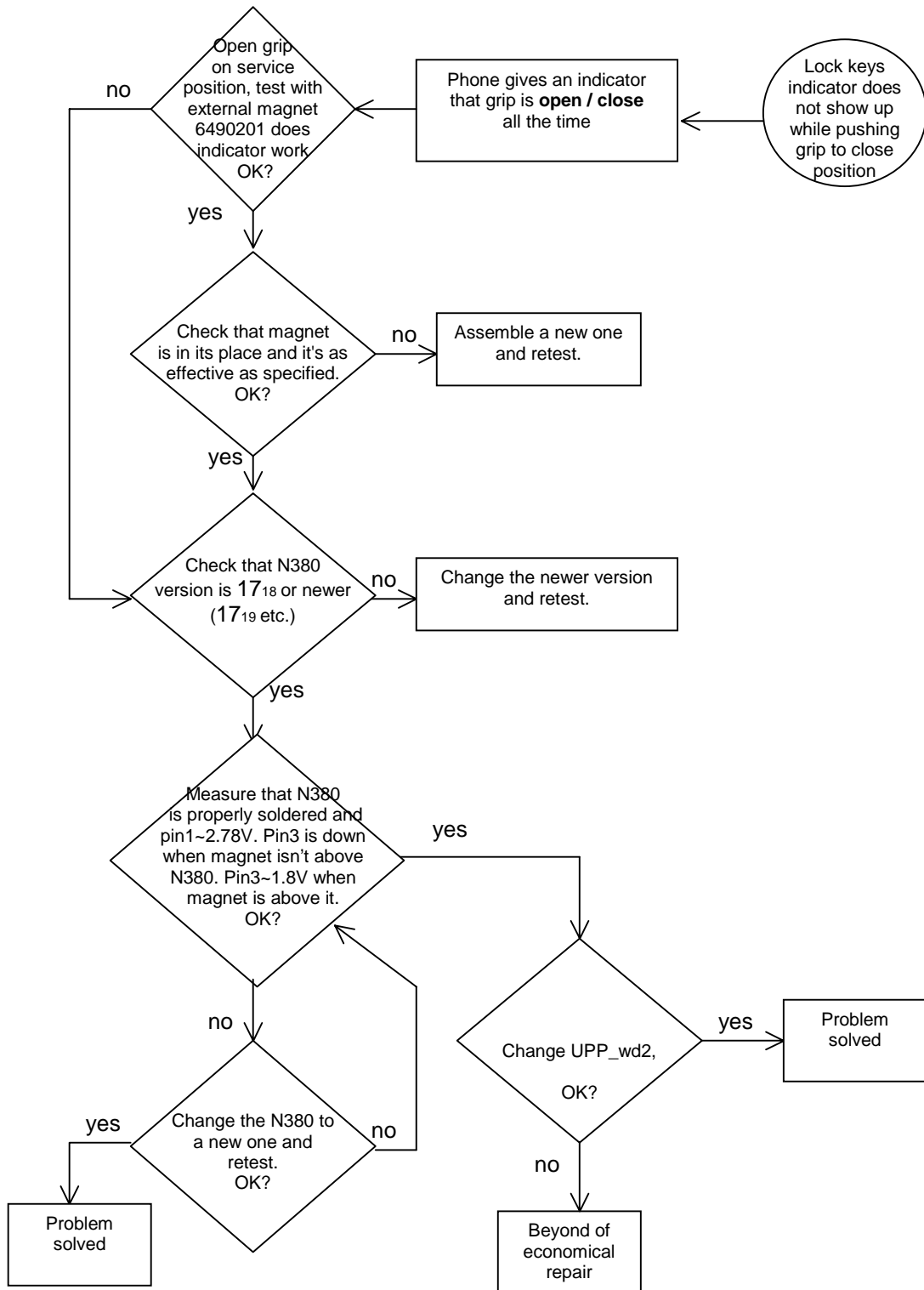

Camera Troubleshooting Instructions

Background, tools and terminology

A fault or complaint associated to camera operation can be roughly categorized to three subgroups:

- 1 Camera is not functional at all, no image can be obtained
- 2 Images can be taken but there is nothing recognizable in them
- 3 Images can be taken and they are recognizable but for some reason the quality of images is seriously degraded, or customer complains about image quality

Type 1 and 2 faults are most often similar to what traditionally has been found in any electronic devices. Type 3 faults are new to NMP and maybe the most challenging to find and verify.

Image quality is very hard to measure quantitatively, and even comparative measurements are difficult (comparing two images) if the difference is small. Especially if the user is not satisfied with his/her devices' image quality, and tells e.g. that the images are not sharp, it is fairly difficult to accurately test the device and get an exact figure which then would tell if the device is OK or not.

Most often, subjective evaluation has to be used for finding out if a certain property of the camera is acceptable or not. Some training or experience of a correctly operating reference device may be needed in order to detect what actually is wrong, or is there anything wrong at all. It is easy for the user to take bad looking images in bad conditions; thus the camera operation has to be checked always in constant conditions (lighting, temperature) or by using a second, known to be good device as a reference. Experience significantly helps in analyzing image quality.

Terms

Dynamic range: camera's ability to capture details in dark and bright areas of the scene simultaneously. See Image which has been taken "against light". The actual object is dark. for example.

Exposure time: camera modules use silicon sensor to collect light and for forming an image. The imaging process roughly corresponds to traditional film photography, in which exposure time means the time during which the film is exposed to light coming through optics. Increasing the time will allow for more light hitting the film and thus results in brighter image. The operation principle is exactly the same with silicon sensor, but the shutter functionality is handled electronically i.e. there is no mechanical moving parts like in film cameras.

Flicker: Phenomena, which is caused by pulsating in scene lighting, typically appearing as wide horizontal stripes in image.

Noise: Variation of response between pixels with same level of input illumination. See e.g. Noisy image taken in +70 degrees celsius for example of noisy image.

Resolution: Usually the amount of pixels in the camera sensor, e.g. VGA means 640 x 480 pixels. In some occasions the term resolution is used for describing the sharpness of the images.

Sensitivity: camera module's sensitivity to light. In equivalent illumination conditions, a less sensitive camera needs longer exposure time to gather enough light for forming a good image. Analogous to ISO speed in photographic film.

Sharpness: camera's images are ideally 'sharp' or 'crisp', meaning that image details are well visible in the picture. However, certain issues like non-idealities in optics, cause image blurring, making objects in picture to appear 'soft'. Each camera type typically has it's own level of performance.

Image taking conditions effect to image quality

This chapter lists some of the factors, which may cause poor image quality if not taken into account by end user when shooting pictures, and thus may result in complaints. **The listed items are normal to camera operation and do not cause a need for e.g. changing the camera module.**

Distance to target: the lens in the module is specified to operate satisfactorily from 30cm to infinite distance of scene objects. In practice, the operation is such that close objects may be noticed to get more blurred when distance to them is shortened from 40cm. Lack of sharpness will be first visible in full resolution (VGA) images. If observing just the viewfinder, even very close objects may seem to appear sharp. *This is normal behavior, do not change the camera module.*

Figure 1: Image blurred due to too close distance to target (5 cm)



Sharpness of picture edges: lens performance degrades in image edges, and generally the image is sharpest in center part. Particularly this applies to distant objects (> 1 meter). With near objects (about 5 cm – 30 cm) the lens behaves so that center of the image may not be the sharpest point, instead maximum sharpness is approximately in half way from center to edges. This phenomena can particularly be seen in images which have

small details over the whole image area, such as grass or similar; See Sharpness of picture is worse on the edges than in the centre. *This is normal behavior, do not change the camera module.*

Figure 2: Sharpness of picture is worse on the edges than in the centre

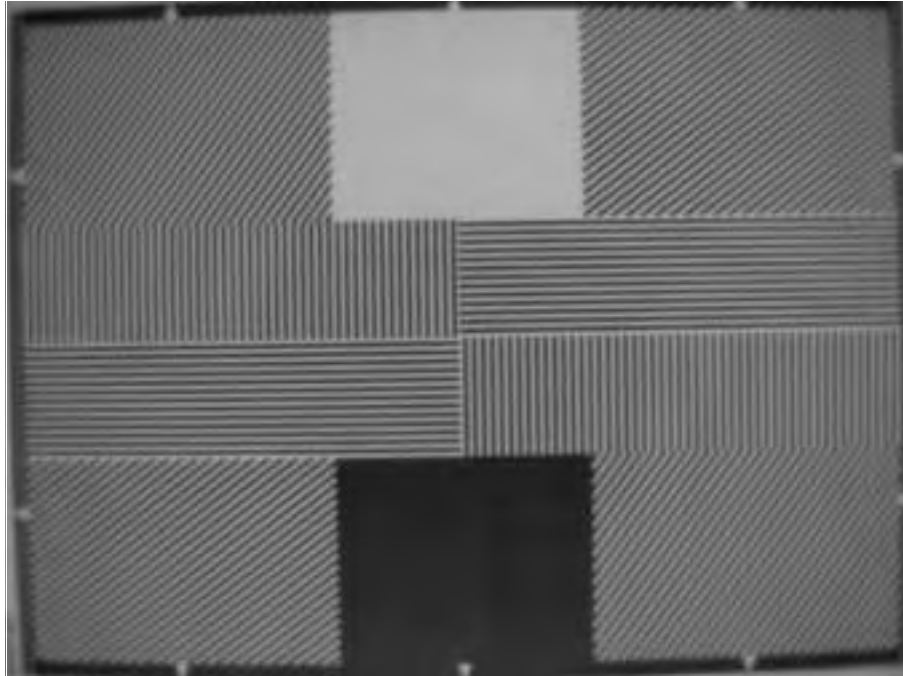

Figure 3: Especially this type of images are affected much by lack of sharpness in edges / corners



Geometrical distortion: camera lens will cause some amount of so called barrel distortion in images. In practice, this appears as bending of straight objects in edges of the image. See Geometrical distortion and Handshake has caused blurring of this image. Note geometrical barrel distortion in background for example. *This is normal behavior, do not change the camera module.*

Figure 4: Geometrical distortion



Amount of light available: in dim conditions camera runs out of sensitivity. Exposure time is long (especially in night mode) and the risk of getting shaken (= blurred) images grows. Image noise level grows. The maximum exposure time in night mode is $\frac{1}{4}$ seconds, so images need to be taken with extreme care and by supporting the phone when the amount of light reflected from the target is low. Sometimes blurring may even happen at daytime if image is taken very carelessly. See Handshake has caused blurring of this image. Note geometrical barrel distortion in background for example. *This is normal behavior, do not change the camera module.*

Figure 5: Handshake has caused blurring of this image. Note geometrical barrel distortion in background



Movement in bright light: If pictures of moving objects are taken or if the device is used in a moving car, object 'skewing' or 'tilting' will occur. This phenomena is fundamental to most CMOS camera types and normal, and can not be helped. Movement of camera or object will usually cause blurring in inside or dim lighting conditions due to long exposure time. *This is normal behavior, do not change the camera module.*

Figure 6: Near objects in image get skewed when shooting from a moving car



Temperature: high temperatures inside the mobile phone will cause more noise to appear in images, e.g. in +70 degrees of celsius the noise level may be very high, and it further grows if the conditions are dim. This is also normal to camera operation. *This is normal behavior, do not change the camera module.*

Figure 7: Noisy image taken in +70 degrees celsius



Phone display: if the display contrast is set too dark, the image quality degrades quite much: the images may be very dark, naturally depending on the setting. If display contrast is set too bright, image contrast appears bad and "faint". This flaw is easily cured by setting the display contrast to correct value. *This is normal behavior, do not change the camera module.*

Basic rules of photography, especially shooting against light: electronic image sensors typically have much lower dynamic range than what films have. In practice this means that when taking a picture inside e.g. having a window behind object, will produce poor results. *This is normal behavior, do not change the camera module.*

Figure 8: Image which has been taken "against light". The actual object is dark.



Flicker: in some occasions a bright fluorescent light may cause flicker to be seen in the viewfinder and captured image. This phenomena may also result if pictures are taken indoors under mismatch of 50/60 Hz electricity network frequency. The frequency will be detected from operator country sign information. In some very few countries, both 50 and 60 Hz networks are present and thus probability for the phenomena grows. *This is normal behavior, do not change the camera module.*

Figure 9: Flicker in image of white, uniform object illuminated by strong fluorescent light



Bright light outside of image view: Especially sun can cause clearly visible 'halo' effects and poor contrast in images. This happens due to unwanted reflections inside camera optics. Generally this kind of reflections are common in all optical systems. *This is normal behavior, do not change the camera module.*

Figure 10: A lens reflection effect caused by sun shining above the scene



Figure 11: A good picture taken indoors



Figure 12: A good picture taken outdoors



Camera construction

In this section, some information of the actual construction of the camera module is given for getting understanding of the actual mechanical structure of the module.

Figure 13: Cross section of the camera module (NMP part # 4858001) and assembly principle (dash line showing phone parts)

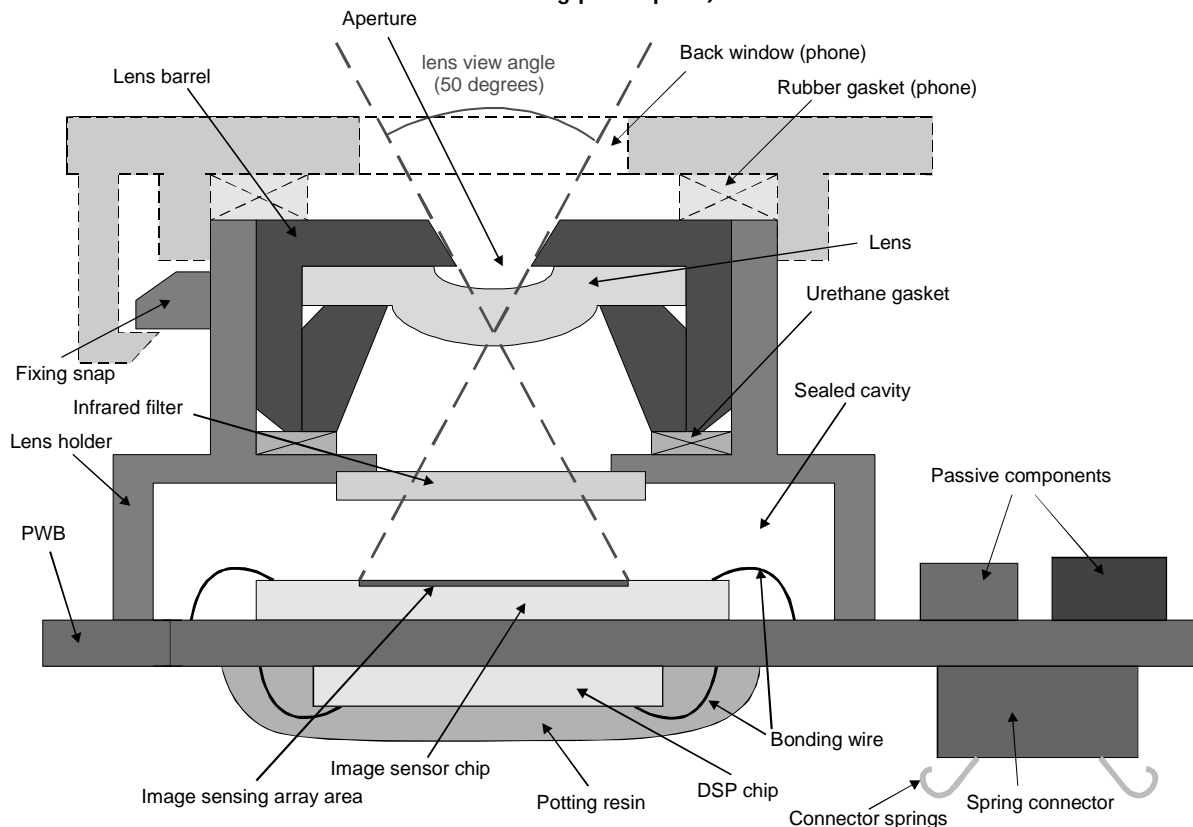

The camera module as a component is not a repairable part i.e. components in the module may not be changed. Cleaning dust from the front face is the only allowable operation, do this by using clean compressed air.

Cross section of the camera module (NMP part # 4858001) and assembly principle (dash line showing phone parts) shows the cross section view of the camera module and the principle of fixing it to a phone. The main parts of the module are

- Threaded lens barrel, containing the lens itself and the lens aperture
- Infrared filter, which is used to prevent infrared light from contaminating the image colors. IR filter is glued to the lens holder
- lens holder, which is made of conductive, metallized plastic and attached to PWB by glue
- Image sensor, which is glued and wire bonded to PWB
- PWB, FR-4 type
- Hard wired DSP chip, which is wire bonded and potted to underside of the module
- Spring connector with 13 contact springs, containing the component type information (laser marked on the surface)
- Passive components

Image quality analysis

Possible faults in image quality

When checking for possible errors in camera functionality, knowing what error is suspected will significantly help the testing by narrowing down the amount of test cases. The following types of image quality problems may be expected to appear (in order of appearance probability):

- Dust (black spots)
- Lack of sharpness
- Bit errors

In addition, there are many other kinds of possibilities for getting bad image quality, but those are ruled out from the scope of this document since probability of their appearance is going to be minimized by production testing.

Testing for dust

For detecting this kind of problems, take an image of uniform white surface and analyze it in full resolution; search carefully – finding these defects is not always easy. Effects of dust in optical path is an example of image containing easily detectable dust problems.

For taking an uniform white image: The best results are obtained using the docking station adapter MJF-7. Care should be taken that the diffuser (white) surface of the adapter is clean.

If adapter is not available, uniform white target such as a clean, straight white sheet of paper, may be used, but extreme care should be taken to arrange illumination conditions so that the target is uniformly illuminated.

Black spots in image are caused by dirt particles trapped into the optical system: clearly visible and sharp edged black dots in image are typically dust particles on image sensor. These spots are searched for in manufacturing phase, but it is possible that the lens holder cavity contains a particle, which may move onto the image sensor active surface, e.g. when the phone is dropped. Thus it is also possible that the problem will disappear before the phone is brought to service. The camera should be replaced if the problem is present when the service technician analyses the phone.

If dust particles are located on infrared filter surface on either side, they are much harder to locate because they will be out of focus, and appear in image as large, grayish and fading-edge 'blobs'. Sometimes they will be very hard to find, and thus the user probably will not notice them at all since they do no harm. But it is possible that a larger particle disturbs the user, causing need for service.

Figure 14: Effects of dust in optical path

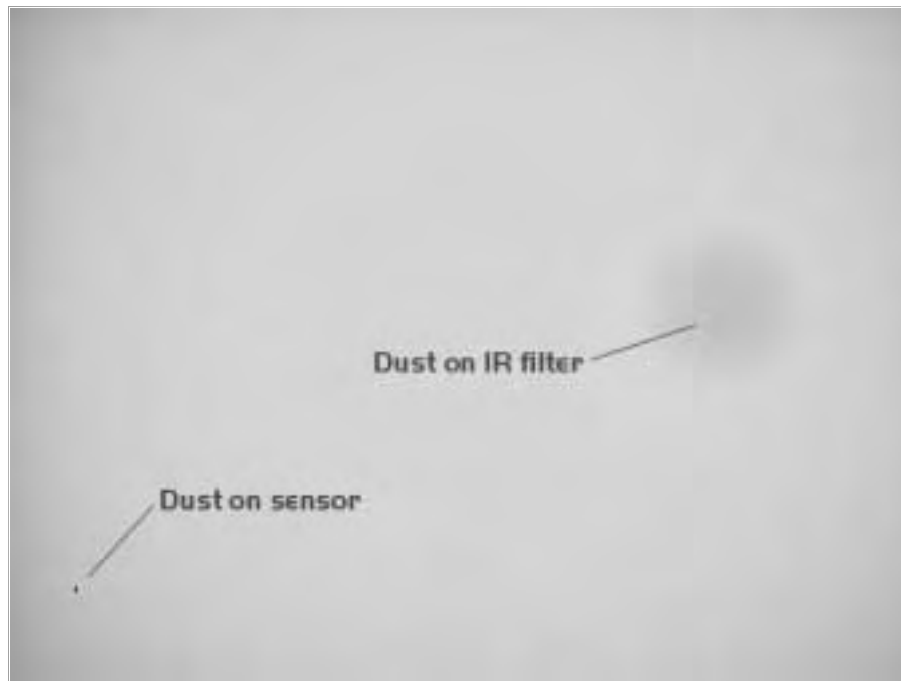

If large dust particles get trapped on top of the lens surface in the cavity between camera window and lens, they will cause image blurring and poor contrast (see also item 'sharpness'). The seal between the window and lens should prevent any particles from getting into the cavity after manufacturing phase.

If dust particles are found on sensor, this is classified as a manufacturing error of the module and thus the camera should be replaced. Any particles inside the cavity between window and lens have most probably been trapped there in assembly phase in Nokia factory. It is of course also possible that the user has disassembled the device and caused the problem. However, in most cases it should be possible to remove the particle(s) by using clean compressed air. Never wipe the lens surface before trying compressed air; the possibility of damaging the lens is substantial. Always check the image sharpness after removing dust.

Testing for sharpness

If pictures taken with some device are claimed to be blurry, there are four possible sources for the claim:

- 1 Back window is fingerprinted, soiled, dirty, visibly scratched or broken
- 2 User has tried to take a picture of a too close object – lens operates with distances from 30 cm to infinity
- 3 User has tried to take pictures in too dark conditions and images are blurred due to handshake or movement. This is no cause to replace camera module
- 4 There is dirt between back window and camera lens
- 5 The back window is defective (somehow passed through window manufacturer's inspection). Window should be changed
- 6 Camera lens is unfocused (somehow passed through camera manufacturer's inspection)

Quantitative analysis of sharpness is very difficult to conduct in other than optics labo-

ratory environment. Thus subjective analysis should be used.

If no visible defects (items 1-4) can be found, a couple of test images should be taken and checked. Generally, a well illuminated typical indoor office scene, such as the one in A good picture taken indoors, can be used as a target. The main considerations are:

- The back window has to be clean
- Amount of light: 300 – 600 lux (bright office lighting) is sufficient
- The scene should contain e.g. small objects for checking sharpness and distance to them should be in order of 1 – 2 meters
- If possible, compare the image to another image of the same scene, taken by different device

The taken images should be analyzed on PC screen at 100% scaling simultaneously with reference image. Pay attention to the computer display settings; at least 65000 colors (16 bit) have to be used. 256 (8-bit) color setting is not sufficient, and true color (24 bit, 16 million colors) or 32 bit (full color) setting is recommended.

If there appears to be a clearly noticeable difference between the reference image and the test images, the module might have misfocused lens. In this case, the module should be changed. Always re-check the resolution after changing the camera. If a different module produces the same result, the fault is probably in camera window. Check the window by seeing through it when replacing the module.

Effects of dirty or defective back window

The following series of images demonstrates the effects of fingerprints on the camera back window.

It should be noted that the effects of any dirt in images can vary very much; it may be difficult to judge if the window has been dirty when some image has been taken or that has something else been wrong. That is why the cleanness of the back window should always be checked and the window should be wiped clean with a suitable cloth.

Figure 15: Image taken with clear back window

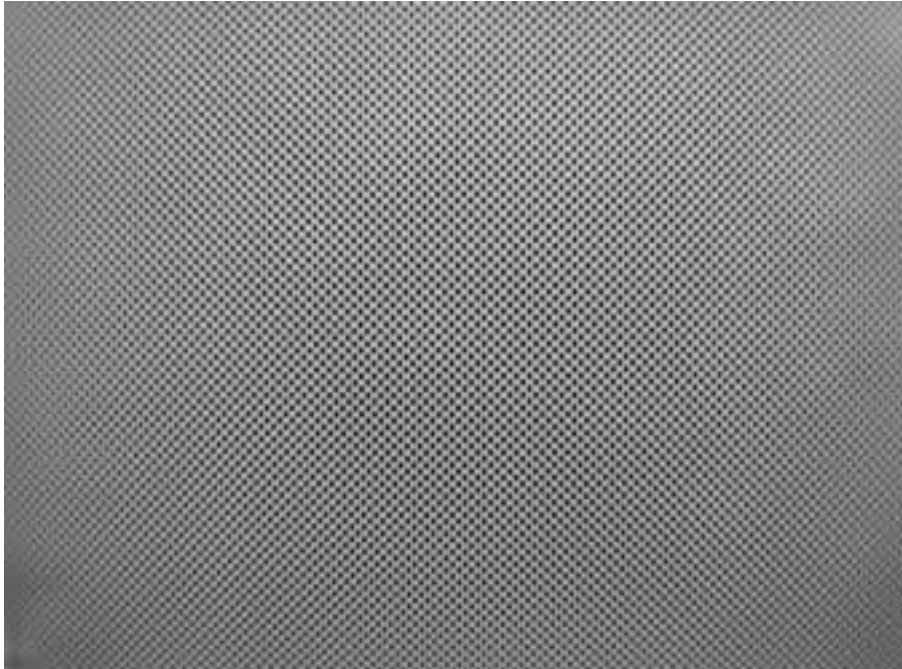

Figure 16: Image taken with a faint fingerprint on back window

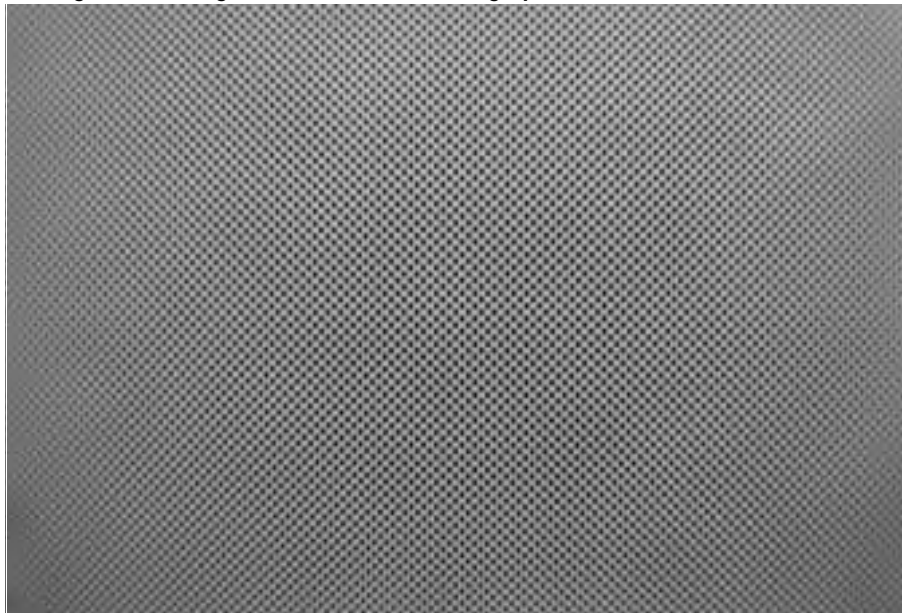

Figure 17: Image taken with a thick fingerprint on back window

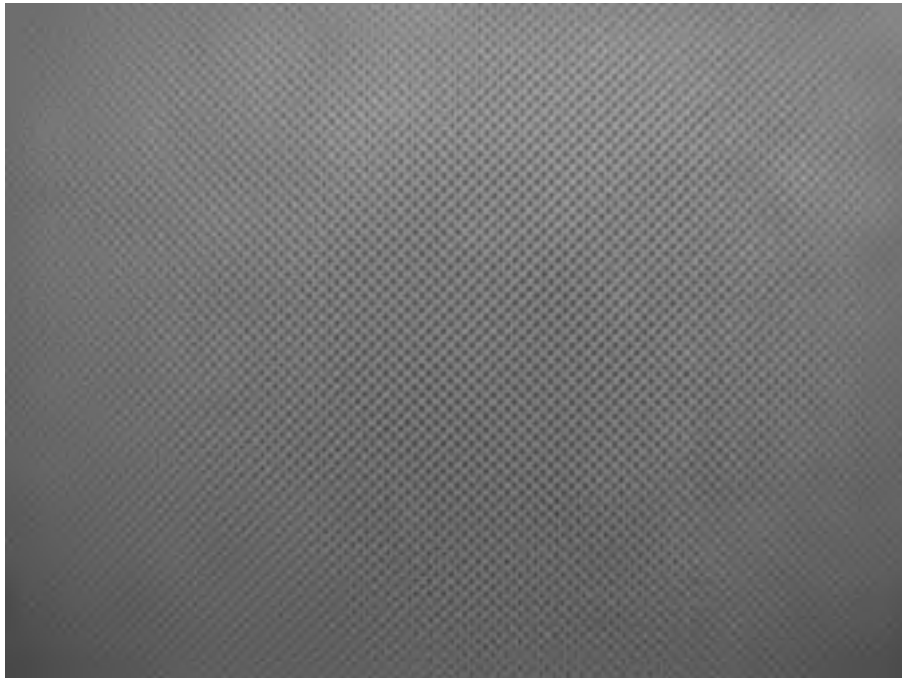

Figure 18: Image taken with badly soiled back window



Figure 19: Natural scene, clear back window**Figure 20: Natural scene, badly soiled back window****Bit errors**

Bit errors are defects in image caused by data transmission error between camera and phone baseband. This type of error is expected to be rare since usually missing bits will cause a hardware failure message. Bit errors can be typically seen in images taken of any object, and they should be most visible in full VGA resolution images. Viewfinder images may not contain the errors at all due to lower bit rate used in this mode. A good practice is to use uniform white test target.

The errors will be clearly visible as colorful sharp dots or lines in camera VGA images.

Typically this is a contact problem between the camera module and LG4. Check camera assembly and spring connector contacts.

Fault finding trees

Hardware failure message

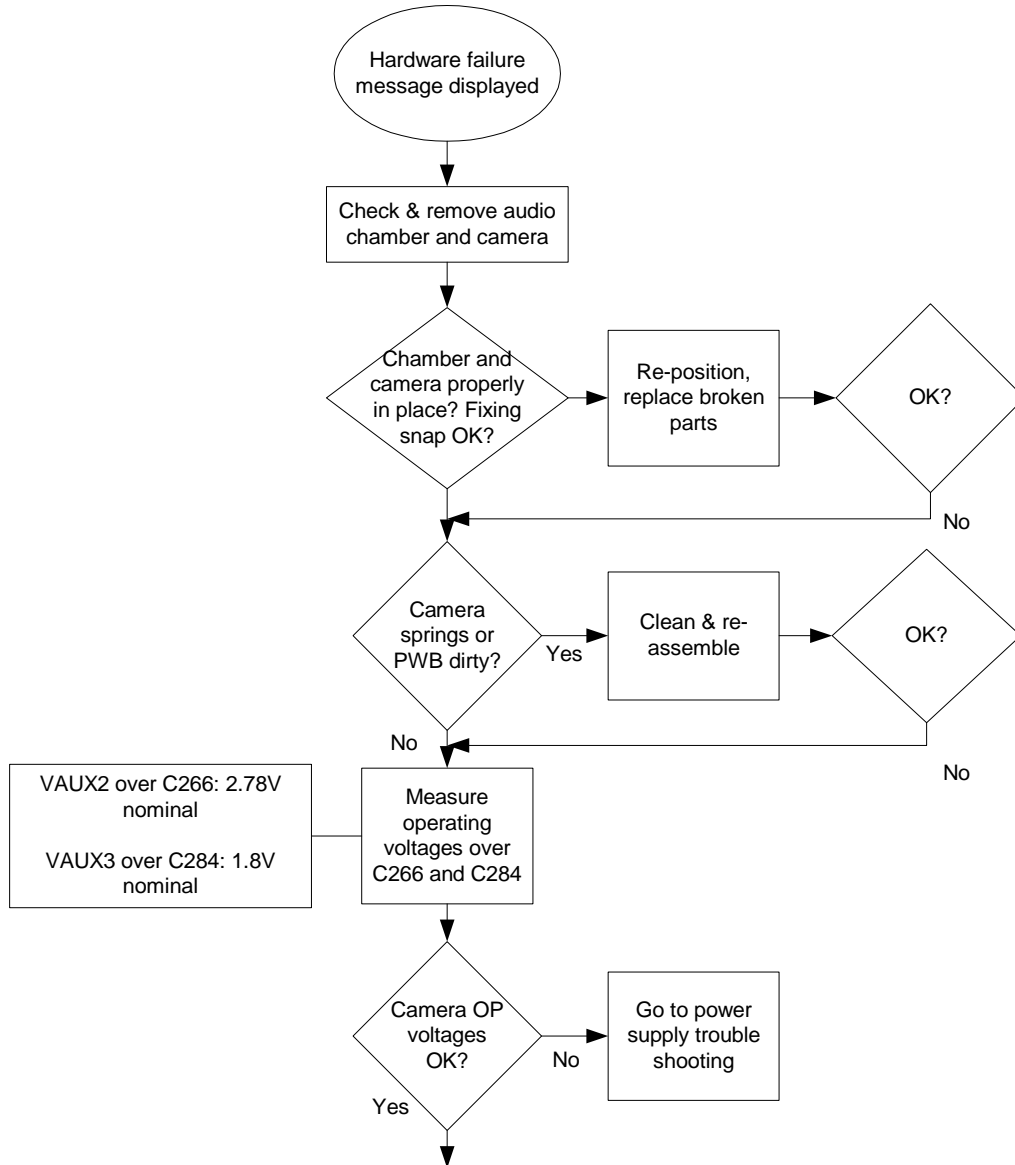

(Continued on next page)

(Continued from previous page)

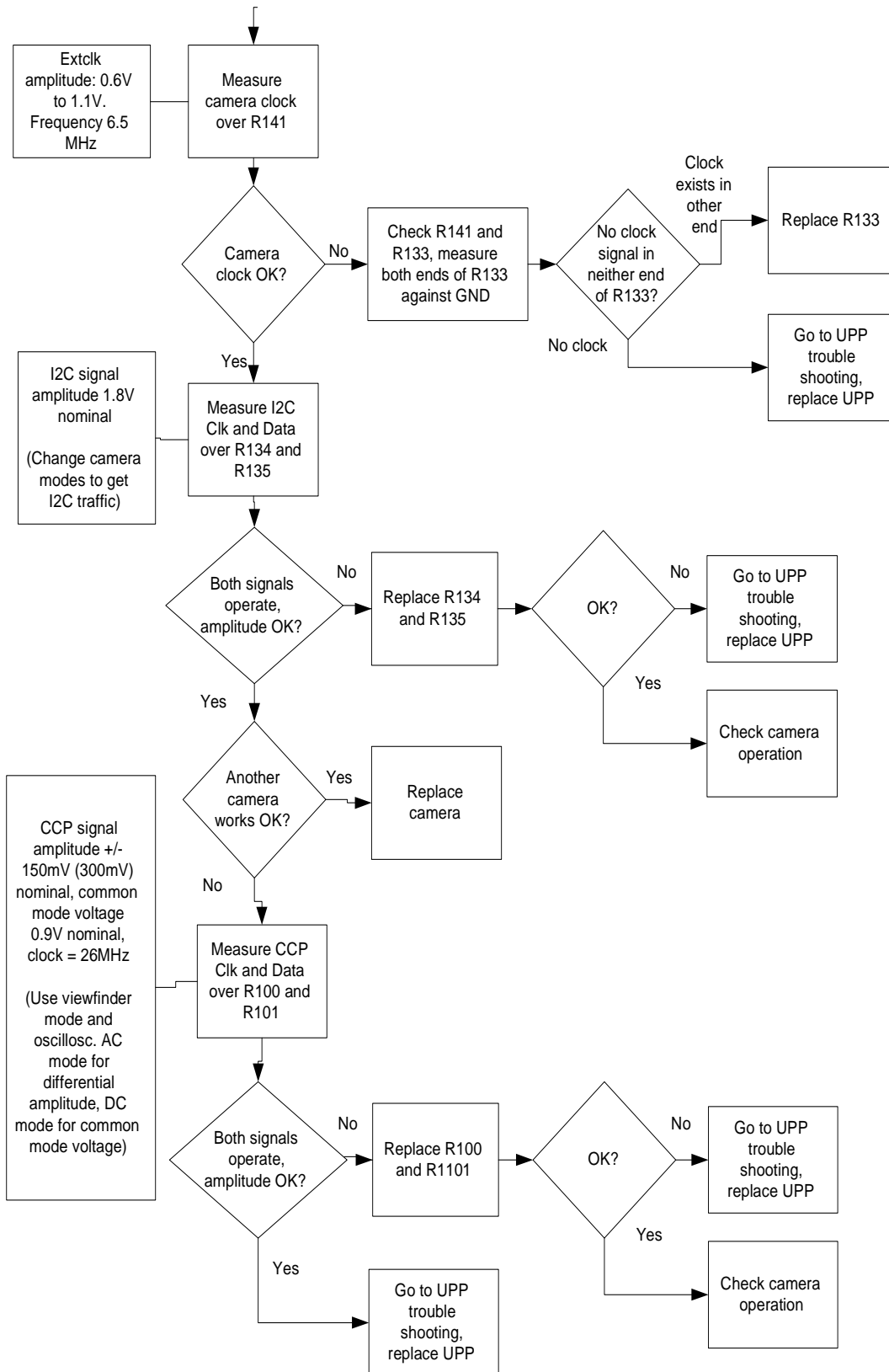

No recognizable viewfinder image

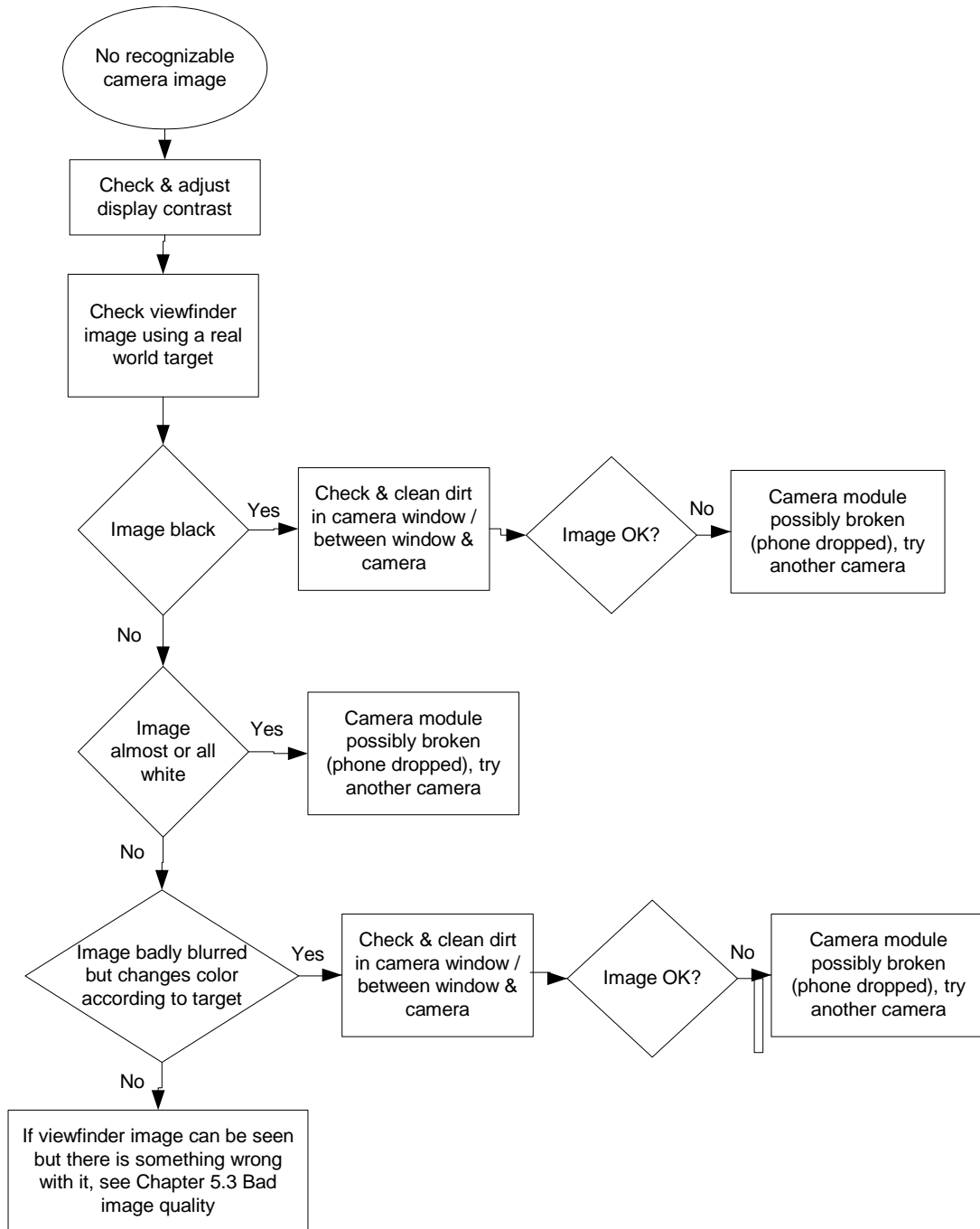

Bad image quality

